

28220 Series

Hygienic Stainless Steel Head Kit Pump

Features

- Self primes from dry up to 5.0 metres
- Flows up to 40 litres per minute
- Pressure up to 3.0 bar†
- Handles soft solids - max. 8mm diameter
- Certified to US 3A Standard 02-10
- Easy strip clean
- Handles viscosities up to 10,000 centiPoise
- Minimal shear to thixotropic fluids
- Fits IEC standard motor B3/B14, frame 80

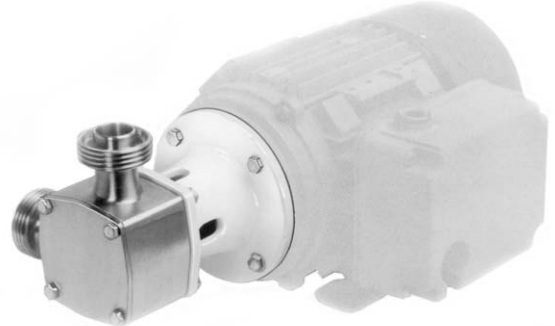

Typical Applications

- Foods, sauces, doughs, preserves, liquid egg, meat pastes
- Dairy products, milk, cream, yoghurt, cheeses
- Cosmetics, toothpaste, shampoos, soaps
- Pharmaceutical creams & lotions
- Wines, beers, soft drinks, fruit juices & syrups
- Ingredients unloading and transfer
- Tank filling and emptying
- Recirculation and mixing
- Portion and container filling
- Brine injection
- Sampling, filtration and more

Model Range

Pressure options	Standard - Max 2.5 bar		High - Max 3.0 bar†	
	3A Neoprene	E.P.D.M.	3A Neoprene	E.P.D.M.
Temperature range	4°C to 70°C	4°C to 100°C	4°C to 70°C	4°C to 100°C
Mechanical Seal Options				
Carbon/Ceramic	28220-x105	28220-x102	28220-x125	28220-x122
Tungsten Carbide/Ceramic hard faced	28220-x205		28220-x225	
Flushed Mechanical Seal				
Tungsten Carbide/Ceramic hard faced	28220-x705		28220-x725	
Carbon/Ceramic	28220-x905		28220-x925	
For models not listed above, consult distributor or factory, 'x' Substitute port code from table above				
Note : it is not recommended to start the pump at extremes of the temperature range, impeller damage may occur				
For Installation, Operating, Maintenance and Safety Instructions refer to form 43001-0543				

Specifications

Seal : Carbon / Ceramic mechanical face seal
Tungsten Carbide / Ceramic hard faced seal
Flushed options for crystallising fluids

Seal Elastomer : Food grade Nitrile

Pump Head : Stainless steel 316, machined interior and electropolished exterior finish

End Cover : Stainless steel 316 grade

Shaft : Stainless steel 316 grade shaft extension

Bearings : Uses motor bearings

Motor Adaptor : Epoxy coated cast iron

Ports :			
1"	Tri-Clamp		28220-1xxx
25mm	IDF/ISS		28220-3xxx
1"	RJT to BS1864		28220-4xxx
1"	3A Bevel Seat		28220-5xxx
25mm	DIN 11851		28220-6xxx
25mm	SMS 1145		28220-7xxx

Weight : 2.5kg

⚠ WARNING Explosion hazard. Do not pump gasoline, solvents, thinners or other flammable liquids. To do so can cause an explosion resulting in injury or death.



† Pressures over 2.5 bar may reduce motor shaft life

JABSCO

040 Size Hygienic Stainless Steel FIP Pump

01/07

Fits IEC motor with foot & face to IEC B3/B14 frame size 80

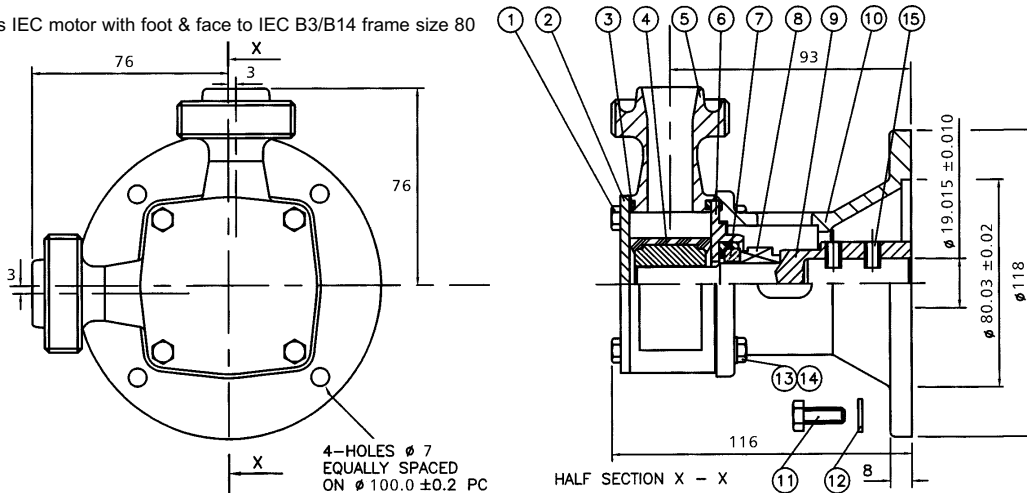
28220 Series

Dimensions in mm

For performance data refer to the 040 size flexible impeller pump performance curves

Flushed Seal

Parts List

Key	Description	Qty	Part Number
1	Screw	4	X3001-147F
2	Endcover	1	28205-0020
3	O'Ring *	2	See right
4	Impeller*	1	See right
5	Body	1	See right
6	Wearplate	1	28236-0000
7 / 8	Seal Assembly *	1	See right
9	Shaft Extension	1	28227-0001
10	Motor Adaptor	1	28223-0000
11	Screw	4	X3001-180F
12	Washer	4	X3080-091K
13	Screw	4	X3001-153F
14	Washer	4	X3080-081F
15	Set Screw	2	X3009-176A
22	O-Ring	1	X4020-237A
23	Seal Housing	1	28212-0000
24	Tube	2	21844
25	Seal	1	SP2701-0913

Parts marked * Contained in service kit

Spare Parts & Service Kits

Pressure Rating		Standard	High
3	O-Ring	Nitrile X4020-259A	X4020-259A
4	Impeller	3A Neoprene	7614-0005B
		E.P.D.M.	7614-0002B
5	Body	Tri-Clamp	28204-1000
		IDF/ISS	28204-3000
		RJT	28204-4000
		Bevel Seat	28204-5000
		DIN	28204-6000
7 / 8	Seals	SMS	28204-7000
		Std Mech.	28231-0103B
Service Kit	3A Neoprene	SK376-0105	SK376-0125
		E.P.D.M.	

Models with Neoprene and E.P.D.M. impellers use Nitrile elastomers on seals and O-rings.
High Temperature impeller part no. 23470-0065B available separately.
NOTE:- Service Kits contain standard mechanical seals. For hard faced seals, order parts separately.

Other Available Options

Pedestal pumps, for higher pressure capability.

**ITT***Engineered for life***Jabsco, 1 Kondelin Road, Cape Ann Industrial Park, Gloucester, MA 01930**

Tel : +1 978 281 0440 Fax : +1 978 283 2619

USA**Jabsco, Bingley Road, Hoddesdon, Hertfordshire, EN11 0BU**

Tel : +44 (0)1992 450145 Fax : +44 (0)1992 467132

UK**Fluid Products Canada, 55 Royal Road, Guelph, Ontario N1H 1T1**

Tel : +1 519 821 1900 Fax : +1 519 821 5316

CANADA**NHK Jabsco Co Ltd, 3-21-10, Shin -Yokohama, Kohoku-ku, Yokohama 222**

Tel : +81 (0) 45 475 8906 Fax : +81 (0) 45 475 8908

JAPAN**Jabsco GmbH, Oststraße 28, 22844 Norderstedt**

Tel : +49 (0) 40 53 53 73 0 Fax : +49 (0) 40 53 53 73 11

GERMANY**Jabsco Italia, s.r.l., Via Tommaseo, 6, 20059 Vimercate, Milano**

Tel : +39 039 685 2323 Fax : +39 039 666 307

ITALY

Warranty: All products of the company are sold and all services of the company are offered subject to the company's warranty and terms and conditions of sale, copies of which will be furnished upon request.
The information provided herein is for guidance only, it does not constitute a guarantee of the performance or specification of any individual product or component.
©Copyright 2006 ITT Corporation

43010-0033