

28420 Series

Hygienic Stainless Steel Head Kit Pump

Features

- Self primes from dry up to 5.0 metres
- Flows up to 200 litres per minute
- Pressure up to 2.5 bar†
- Handles soft solids - max. 16mm diameter
- Certified to US 3A Standard 02-10
- Easy strip clean
- Handles viscosities up to 10,000 centiPoise
- Minimal shear to thixotropic fluids
- Fits IEC standard motor B3/B14, frame 90



Typical Applications

- Foods, sauces, doughs, preserves, liquid egg, meat pastes
- Dairy products, milk, cream, yoghurt, cheeses
- Cosmetics, toothpaste, shampoos, soaps
- Pharmaceutical creams & lotions
- Wines, beers, soft drinks, fruit juices & syrups
- Ingredients unloading and transfer
- Tank filling and emptying
- Recirculation and mixing
- Portion and container filling
- Brine injection
- Sampling, filtration and more

Specifications

Seal : Carbon / Ceramic mechanical face seal
Tungsten Carbide / Ceramic hard faced seal
Flushed options for crystallising fluids

Seal Elastomer : Food grade Nitrile

Pump Head : Stainless steel 316, machined interior and electropolished exterior finish

End Cover : Stainless steel 316 grade

Shaft : Stainless steel 316 grade shaft extension

Bearings : Uses motor bearings

Motor Adaptor : Epoxy coated cast iron

| Ports : | | | |
|---------|---------------|--|------------|
| 1½" | Tri-Clamp | | 28420-1xxx |
| 38mm | IDF/ISS | | 28420-3xxx |
| 1½" | RJT to BS1864 | | 28420-4xxx |
| 1½" | 3A Bevel Seat | | 28420-5xxx |
| 40mm | DIN 11851 | | 28420-6xxx |
| 38mm | SMS 1145 | | 28420-7xxx |

Model Range

Weight : 6.6kg

| Pressure options | Medium - Max 2.5 bar† | | | |
|--|-----------------------|--------------|--|--|
| Elastomer option | 3A Neoprene | E.P.D.M. | | |
| Temperature range | 4°C to 70°C | 4°C to 100°C | | |
| Mechanical Seal Options | | | | |
| Carbon/Ceramic | 28420-x115 | | | |
| Tungsten Carbide/Ceramic hard faced | 28420-x215 | | | |
| Flushed Mechanical Seal | | | | |
| Tungsten Carbide/Ceramic hard faced | 28420-x715 | | | |
| Carbon/Ceramic | | | | |
| For models not listed above, consult distributor or factory, 'x' Substitute port code from table above | | | | |
| Note : it is not recommended to start the pump at extremes of the temperature range, impeller damage may occur | | | | |
| For Installation, Operating, Maintenance and Safety Instructions refer to form 43001-0543 | | | | |



WARNING Explosion hazard. Do not pump gasoline, solvents, thinners or other flammable liquids. To do so can cause an explosion resulting in injury or death.

† Pressures over 1.4 bar may reduce motor shaft life

JABSCO®

200 Size Hygienic Stainless Steel FIP Pump

01/07

Fits IEC motor with foot & face to IEC B3/B14 frame size 90

28420 Series

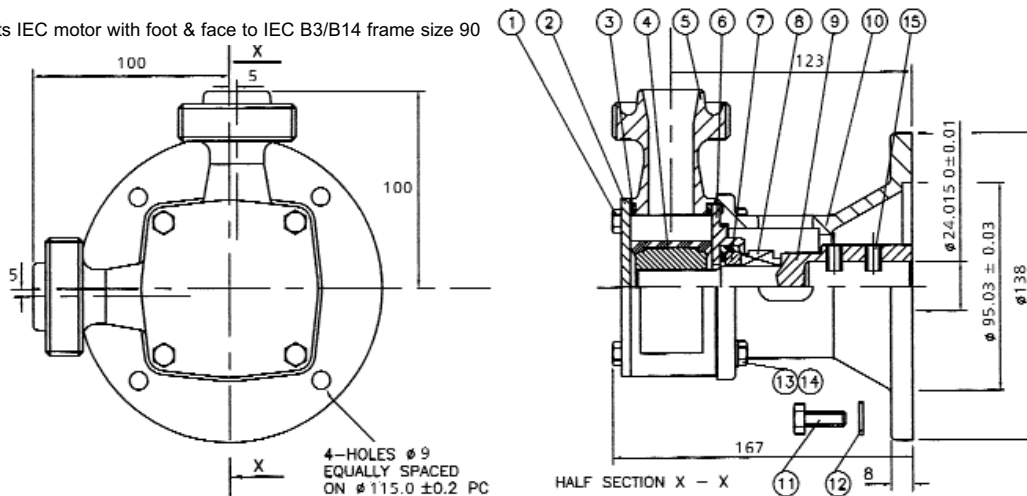

Flushed Seal

Dimensions in mm

For performance data refer to the 200 size flexible impeller pump performance curves

Parts List

| Key | Description | Qty | Part Number |
|-------|-----------------|-----|-------------|
| 1 | Screw | 4 | X3001-207F |
| 2 | Endcover | 1 | 28405-0020 |
| 3 | O'Ring * | 2 | See right |
| 4 | Impeller* | 1 | See right |
| 5 | Body | 1 | See right |
| 6 | Wearplate | 1 | 28436-0000 |
| 7 / 8 | Seal Assembly * | 1 | See right |
| 9 | Shaft Extension | 1 | 28427-0001 |
| 10 | Motor Adaptor | 1 | 28423-0000 |
| 11 | Screw | 4 | X3001-209F |
| 12 | Washer | 4 | X3080-101K |
| 13 | Screw | 4 | X3001-209F |
| 14 | Washer | 4 | X3080-101F |
| 15 | Set Screw | 2 | X3009-207A |
| 22 | O-Ring | 1 | X4020-261A |
| 23 | Seal Housing | 1 | 28412-0000 |
| 24 | Tube | 2 | 21844 |
| 25 | Seal | 1 | SP2701-0915 |

Parts marked * Contained in service kit

Spare Parts & Service Kits

| Pressure Rating | Medium | |
|-----------------|-------------|-------------|
| 3 O-Ring | Nitrile | X4020-399A |
| 4 Impeller | 3A Neoprene | 14346-0005B |
| | E.P.D.M. | 14346-0002B |
| 5 Body | Tri-Clamp | 28404-1000 |
| | IDF/ISS | 28404-3000 |
| | RJT | 28404-4000 |
| | Bevel Seat | 28404-5000 |
| | DIN | 28404-6000 |
| 7 / 8 Seals | SMS | 28404-7000 |
| | Std Mech. | 28431-0103B |
| Service Kit | Hard Faced | 28431-0203B |
| | 3A Neoprene | SK378-0115 |
| | E.P.D.M. | |

Models with Neoprene and E.P.D.M. impellers use Nitrile elastomers on seals and O-rings.

NOTE:- Service Kits contain standard mechanical seals. For hard faced seals, order parts separately.

Other Available Options

Pedestal pumps, for higher pressure capability.

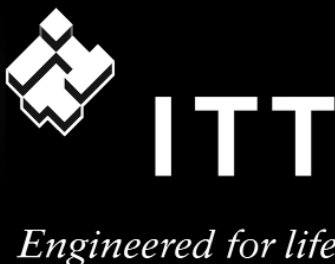

Jabsco, 1 Kondelin Road, Cape Ann Industrial Park, Gloucester, MA 01930
Tel : +1 978 281 0440 Fax : +1 978 283 2619

USA

Jabsco, Bingley Road, Hoddesdon, Hertfordshire, EN11 0BU
Tel : +44 (0)1992 450145 Fax : +44 (0)1992 467132

UK

Fluid Products Canada, 55 Royal Road, Guelph, Ontario N1H 1T1
Tel : +1 519 821 1900 Fax : +1 519 821 5316

CANADA

NHK Jabsco Co Ltd, 3-21-10, Shin - Yokohama, Kohoku-ku, Yokohama 222
Tel : +81 (0) 45 475 8906 Fax : +81 (0) 45 475 8908

JAPAN

Jabsco GmbH, Oststraße 28, 22844 Norderstedt
Tel : +49 (0) 40 53 53 73 0 Fax : +49 (0) 40 53 53 73 11

GERMANY

Jabsco Italia, s.r.l., Via Tommaseo, 6, 20059 Vimercate, Milano
Tel : +39 039 685 2323 Fax : +39 039 666 307

ITALY

Warranty: All products of the company are sold and all services of the company are offered subject to the company's warranty and terms and conditions of sale, copies of which will be furnished upon request. The information provided herein is for guidance only, it does not constitute a guarantee of the performance or specification of any individual product or component.

©Copyright 2006 ITT Corporation

43010-0035