

Committed to Our Customers

Committed to Our Customers

Committed to Our Customers

High Quality

Cost-Effective

Timely Delivery

Advanced Design

Super Reliability

Excellent Performance



Pan World

Leader in Leak-free Technology

TECHNIQUES DES FLUIDES

Tél.: 01.34.11.13.73 ☐

Fax: 01.34.11.96.35 ☐

www.techniquesfluides.fr ☐

tdf@techniquesfluides.fr ☐

PX Series (Glass Fibre-reinforced PP)

Compact Magnetic Drive Pump for OEM Applications

- OEM and general applications.
- 14 models with flow rates up to 80 lit/min.
- Offering ceramic bearing & ceramic spindle as standard wearing parts to achieve long life expectancy.
- Standard connections available in hose, threads or union type.

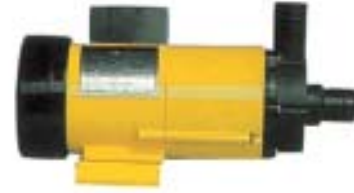

Specification table

Nominal speed 2,500/3,000 r.p.m

Model	Connection method			Performance M-L/min, 50~60Hz		Motor
	Hose (mm)	Thread (")	Union (A)	Max total head-max discharge	Specified head-specified discharge	Output x Input (W)
	In x Outlet	In x Outlet	In x Outlet			
1PX	14A x 14A	G1/2 x 1/2	-----	0.9-7.0/1.2-8.0	0.7-2.6/0.8-4.5	2.5-17/18
1PX-Z	14A x 14A	G1/2 x 1/2	-----	2.0-5.5/2.8-7.0	1.5-3.0/1.5-4.3	5-20/21
3PX	14A x 14A	G1/2 x 1/2	-----	1.4-10.0/2.0-11.5	1.0-4.8/1.0-7.5	5-19/20
5PX	14A x 14A	G1/2 x 1/2	-----	0.9-7.0/1.2-8.0	0.7-2.6/0.8-4.5	2.5-17/18
5PX-Z	14A x 14A	G1/2 x 1/2	-----	2.0-5.5/2.8-7.0	1.5-3.0/1.5-4.3	5-20/21
10PX	14A x 14A	G1/2 x 1/2	-----	1.4-10.0/2.0-11.5	1.0-4.8/1.0-7.5	5-19/20
30PX	14A x 14A	G3/4 x 3/4	16A x 16A	2.1-15.0/3.1-18.0	1.5-7.0/1.5-13.0	10-29/30
40PX	18A x 18A	G3/4 x 3/4	16A x 16A	2.6-25.0/4.1-30.0	2.0-14.0/2.0-22.0	20-40/45
50PX-Z	18A x 18A	G3/4 x 3/4	16A x 16A	4.8-9.5/6.7-11.0	4.0-3.5/4.0-8.0	20-55/55
50PX	20A x 20A	G3/4 x 3/4	16A x 16A	3.5-30.0/5.0-37.0	2.5-15.0/2.5-24.0	45-65/90
50PX-X	26A x 26A	G1 x 1	20A x 20A	2.8-55.0/4.0-52.0	2.0-30.0/2.0-40.0	45-65/80
100PX-Z	18A x 18A	G3/4 x 3/4	16A x 16A	8.0-14.0/11.0-18.0	5.0-9.0/6.0-13.0	45-80/95
100PX	20A x 20A	G3/4 x 3/4	16A x 16A	4.2-43.0/6.3-50.0	4.0-20.0/4.0-31.0	65-90/120
100PX-X	26A x 26A	G1 x 1	20A x 20A	3.0-70.0/4.0-80.0	2.0-45.0/2.0-60.0	65-120/165
100PX-ZZ	20A x 20A	G3/4 x 3/4	20A x 20A	11.5-22.0/13.5-24.0	9.5-10.0/6.0-2.0	65-140/200

Pump performance curve

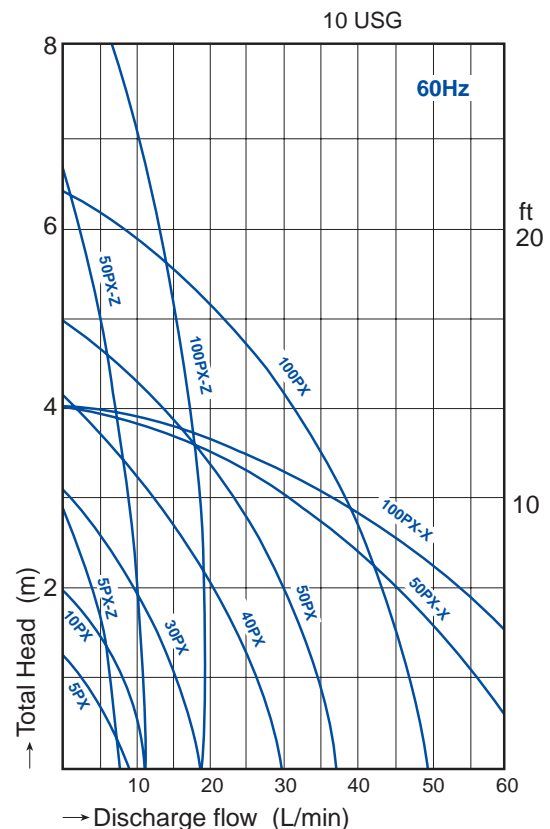
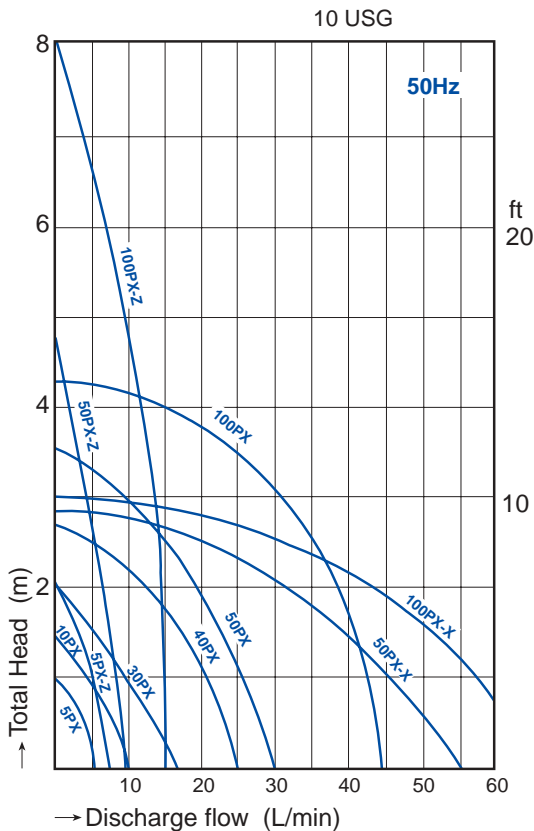

Note: Performance of (1PX, 6PX = 5PX) / (1PX-Z, 6PX-Z = 5PX-Z) / (3PX, 7PX = 10PX)

PX-N Series (Natural)

Compact Magnetic Drive Pump for Semiconductor Application

- With PvdF natural wetted-end and ceramic or Sic bearing & spindle, these pumps are well made for semiconductor application.
- 14 models with flow rates up to 80 lit/min.
- Standard connections available in hose, threads or union type.



PX-F Series (Carbon Fibre-reinforced ETFE)

Compact Magnetic Drive Pump for hazardous chemical transfer

- ETFE wetted-end material for highly hazardous chemical transfer.
- 8 models with flow rates up to 80 lit/min.
- Standard connections available in hose, threads or union type.



Pump performance curve

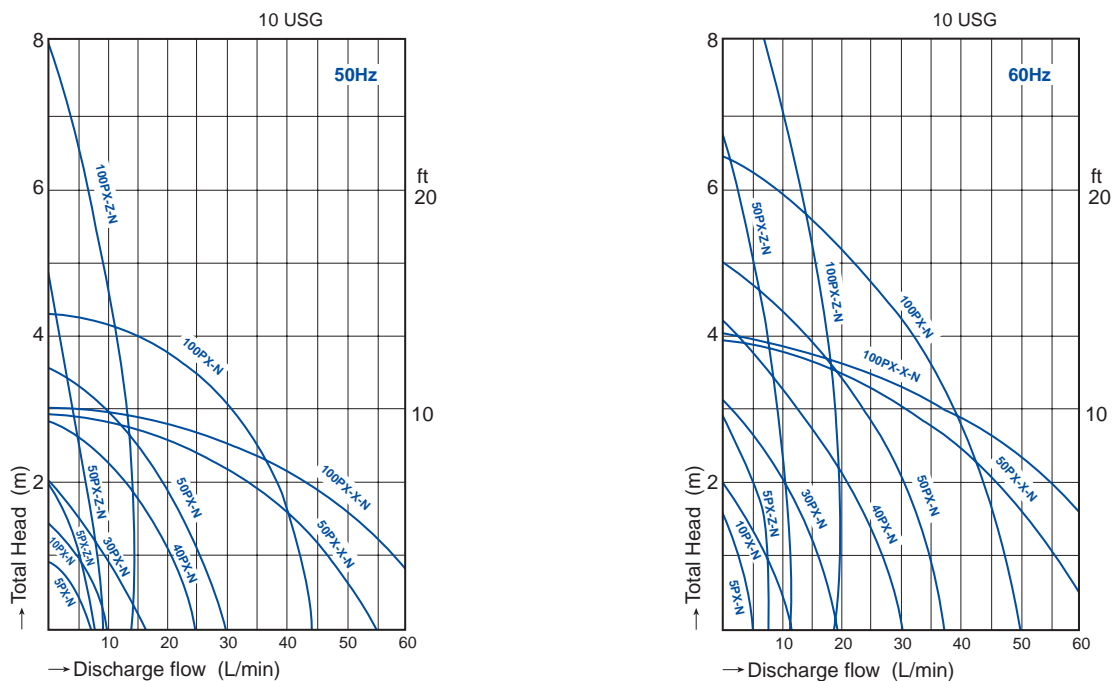

Note: Performance of (1PX-N, 6PX-N = 5PX-N) / (1PX-Z-N, 6PX-Z-N = 5PX-Z-N) / (3PX-N, 7PX-N = 10PX-N)

Specification table

Nominal speed 2,500/3,000 r.p.m

Model	Connection method			Performance M-L/min, 50-60Hz		Motor
	Hose (mm)	Thread (")	Union (A)	Max total head-max discharge	Specified head-specified discharge	Output x Input (W)
	In x Outlet	In x Outlet	In x Outlet			
1PX-N	14 x 14	G1/2 x 1/2	----	0.9-7.0/1.2-8.0	0.7-2.6/0.8-4.5	2.5-17/18
1PX-Z-N	14 x 14	G1/2 x 1/2	----	2.0-5.5/2.8-7.0	1.5-3.0/1.5-4.3	5-20/21
3PX-N	14 x 14	G1/2 x 1/2	----	1.4-10.0/2.0-11.5	1.0-4.8/1.0-7.5	5-19/20
5PX-N	14 x 14	G1/2 x 1/2	----	0.9-7.0/1.2-8.0	0.7-2.6/0.8-4.5	2.5-17/18
5PX-Z-N	14 x 14	G1/2 x 1/2	----	2.0-5.5/2.8-7.0	1.5-3.0/1.5-4.3	5-20/21
10PX-N	14 x 14	G1/2 x 1/2	----	1.4-10.0/2.0-11.5	1.0-4.8/1.0-7.5	5-19/20
30PX-N/30PX-F	14 x 14	G3/4 x 3/4	16A x 16A	2.1-15.0/3.1-18.0	1.5-7.0/1.5-13.0	10-29/30
40PX-N/40PX-F	18 x 18	G3/4 x 3/4	16A x 16A	2.6-25.0/4.1-30.0	2.0-14.0/2.0-22.0	20-40/45
50PX-Z-N/50PX-Z-F	18 x 18	G3/4 x 3/4	16A x 16A	4.8-9.5/6.7-11.0	4.0-3.5/4.0-8.0	20-55/55
50PX-N/50PX-F	20 x 20	G3/4 x 3/4	16A x 16A	3.5-30.0/5.0-37.0	2.5-15.0/2.5-24.0	45-65/90
50PX-X-N/50PX-X-F	26 x 26	G1 x 1	20A x 20A	2.8-55.0/4.0-70.0	2.0-30.0/2.0-40.0	45-65/80
100PX-Z-N/100PX-Z-F	18 x 18	G3/4 x 3/4	16A x 16A	8.0-14.0/11.0-18.0	5.0-9.0/6.0-13.0	45-80/95
100PX-N/100PX-F	20 x 20	G3/4 x 3/4	16A x 16A	4.2-43.0/6.3-50.0	4.0-20.0/4.0-31.0	65-90/120
100PX-X-N/100PX-X-F	26 x 26	G1 x 1	20A x 20A	3.0-70.0/4.0-80.0	2.0-45.0/2.0-60.0	65-120/165
100PX-ZZ-N/100PX-ZZ-F	20 x 20	G3/4 x 3/4	20A x 20A	11.5-22.0/13.5-24.0	9.5-10.0/6.0-20	65-140/200

PX-D Series (Glass-filled Polypropylene)

PX-D-N Series (Pvdf Natural)

PX-D-F Series (Carbon Fibre-filled ETFE)



Magnetic Drive Pump with Computer-controlled DC brush-less motor, fixed-speed & variable-speed

- Magnetic Drive Pump equipped with DC brush-less motor, printed circuit board & variable speed controller.
- Wetted-end materials in PP, Pvdf or ETFE to meet different requirements.
- Can accept external 4-20mA for maintaining constant flow and pressure and also pH adjustment.
- Motor efficiency doubles that of the AC type.
- Space saving.

Specification table

Model	Connection method			Maximum Performance					
	Wetted end	Hose	Thread (")	Union (A)	Head(M) - Discharge flow (L/min)				
Polypropylene/Pvdf/ETFE	In x Outlet	In x Outlet	In x Outlet		2,000r.p.m	2,500r.p.m	3,000r.p.m	3,500r.p.m	4,000r.p.m
5PX-D, 5PX-D-N	14A x 14A	G1/2 x 1/2	-----	-----	-----	0.9-8.5	1.2-11.5	1.9-13.5	2.8-15.0
10PX-D, 10PX-D-N	14A x 14A	G1/2 x 1/2	-----	-----	-----	1.2-10.0	1.6-12.0	2.5-13.0	-----
NH-5PX-Z-D, 5PX-Z-D-N	14A x 14A	G1/2 x 1/2	-----	-----	-----	1.5-8.0	2.2-10.0	2.8-12.0	-----
NH-30PX-D/30PX-D-N 30PX-D-F	14A x 14A	G3/4 x 3/4	16A x 16A	1.2-14.5	1.6-16.0	2.6-17.0	3.6-22.0	-----	-----
NH-40PX-D/40PX-D-N 40PX-D-F	18A x 18A	G3/4 x 3/4	16A x 16A	1.7-18.0	2.3-22.0	3.1-26.0	3.9-30.0	-----	-----
NH-50PX-Z-D/50PX-Z-D-N 50PX-Z-D-F	18A x 18A	G3/4 x 3/4	16A x 16A	2.6-12.0	4.2-13.0	5.0-13.5	-----	-----	-----

Pump performance curve

5PX-D/5PX-D-N

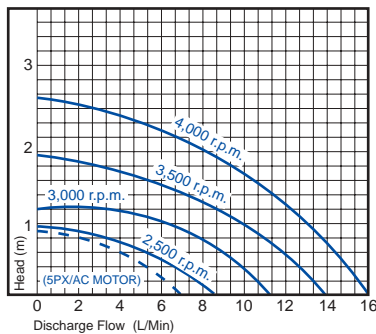

5PX-Z-D/5PX-Z-D-N

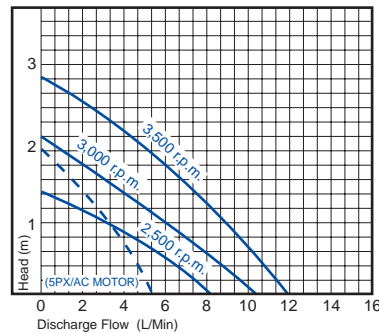

10PX-D/10PX-D-N

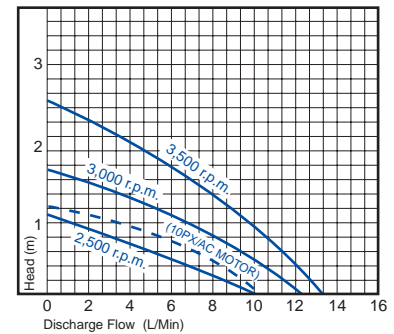

30PX-Z-D/30PX-Z-D-N/30PX-Z-D-F

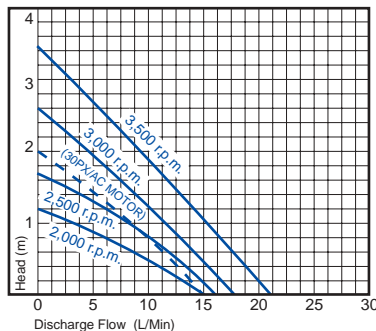

40PX-Z-D/40PX-Z-D-N/40PX-Z-D-F

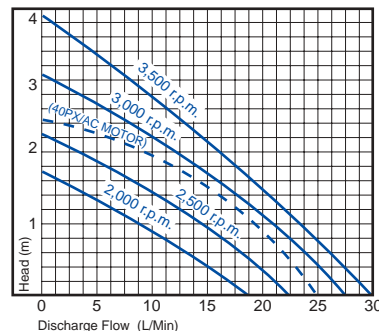

50PX-Z-D/50PX-Z-D-N/50PX-Z-D-F

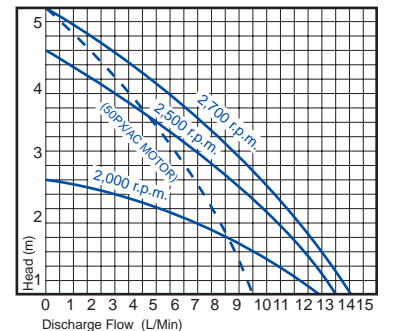

Note: 1. Broken line shows pump performance of PX Series with AC motor.

PX-SP Series (Glass Fiber reinforced PP)

Compact Magnetic Driven Pump With Self Priming Chamber

- Suitable for application of negative suction lift head.
- 6 models with flow rate up to 50 lit/min.
- Offering ceramic bearing & ceramic spindle as wetted end parts.
- Standard connections available in hose, thread and union.
- 1.2 m suction lift at S.G. 1.0 is available.
- Top mount on to drum can is acceptable for replacement of drum pump.



Pump performance curve

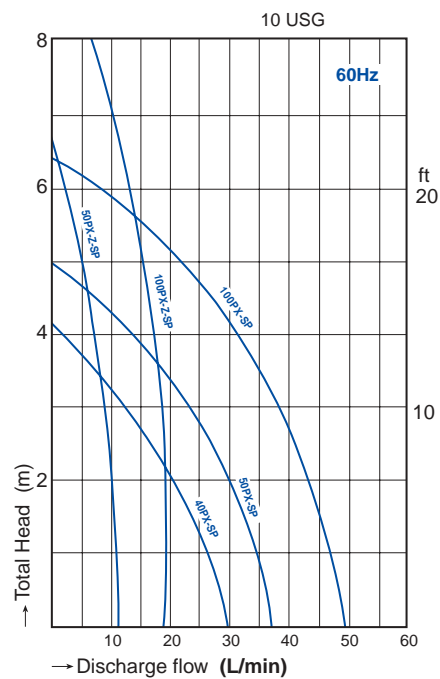
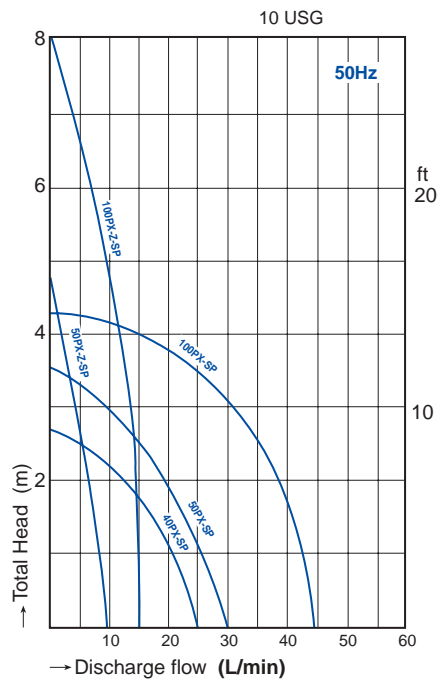

Specification table

Nominal speed 2,500/3,000 r.p.m

Model	Connection method			Performance M-L/min, 50-60Hz		Max Suction Lift Head (m)	Motor	
	Hose (mm)	Thread (")	Union (A)	Max total head- 50Hz / 60Hz	Specified head- 50Hz / 60Hz			Output x Input (W)
	In x Outlet	In x Outlet	In x Outlet					
40PX-SP	18A x 18A	G3/4 x 3/4	16A x 16A	2.6-25.0/4.1-30.0	2.0-14.0/2.0-22.0	1.2	20-40/45	
50PX-Z-SP	18A x 18A	G3/4 x 3/4	16A x 16A	4.8-9.5/6.7-11.0	4.0-3.5/4.0-8.0	1.2	20-55/55	
50PX-SP	20A x 20A	G3/4 x 3/4	16A x 16A	3.5-30.0/5.0-37.0	2.5-15.0/2.5-24.0	1.2	45-65/90	
100PX-Z-SP	18A x 18A	G3/4 x 3/4	16A x 16A	8.0-14.0/11.0-18.0	5.0-9.0/6.0-13.0	1.2	45-80/95	
100PX-SP	20A x 20A	G3/4 x 3/4	16A x 16A	4.2-43.0/6.3-50.0	4.0-20.0/4.0-31.0	1.2	65-90/120	

PS Series (PPG)

General Purpose Magnetic Drive Pumps

- OEM & general applications.
- 8 models with flow rates up to 110 lit/min.
- Available in hose, threaded and flange connections.
- Cost saving PP wetted-end material.



Specification table

Nominal speed 2,700/3,200 r.p.m

Model	Connection method				Performance, M-L/min, 50-60Hz		Motor
	Hose (mm)	Thread (")	Union (A)	Flange (A)	Max total head-max discharge	Specified head-specified discharge	Output x Input (W)
	In x Outlet	In x Outlet	In x Outlet	In x Outlet			
125PS (N)	25 x 25	NPT1x1, G1x1	20	25 x 25	3.3-75/4.7-85	2.0-47/2.0-65	65 - 90/130
150PS	25 x 25	NPT1x1, G1x1	20	25 x 25	5.6-60/8.2-70	4-30/4-45	90 - 130/170
200PS-Z	25 x 25	NPT1x1, G1x1	20	25 x 25	12.5-35/16-37	9-20/8-30	150 - 290
200PS	25 x 25	NPT1x1, G1x1	20	25 x 25	10-90/12-110	6.5-50/7.5-70	150 - 290
200PS-3	25 x 25	NPT1x1, G1x1	20	25 x 25	10-90/12-110	6.5-50/7.5-70	150 - 290
250PS	25 x 25	NPT1x1, G1x1	20	25 x 25	12.5-120/14-120	9-65/9-80	250 - 390
250PS-3	25 x 25	NPT1x1, G1x1	20	25 x 25	12.5-120/14-120	9-65/9-80	250 - 390
250PS-3E	25 x 25	NPT1x1, G1x1	20	25 x 25	12.5-120/14-120	9-65/9-80	JEM - 0.2kW

Pump performance curve

NH-200PS 50Hz Nominal speed 2,700 r.p.m

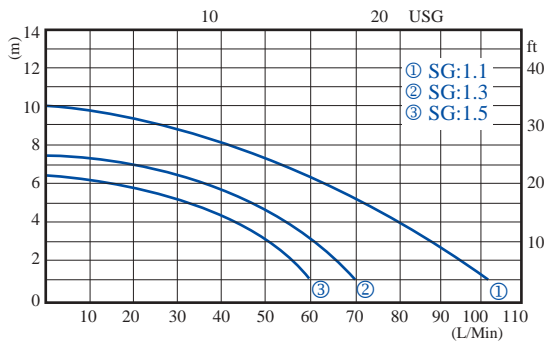

NH-200PS 60Hz Nominal speed 3,300 r.p.m

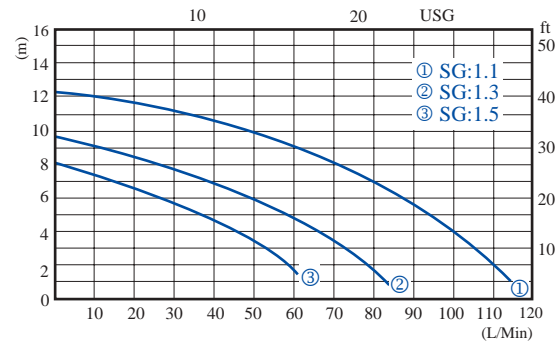

NH-200PS-Z 50Hz Nominal speed 2,500 r.p.m

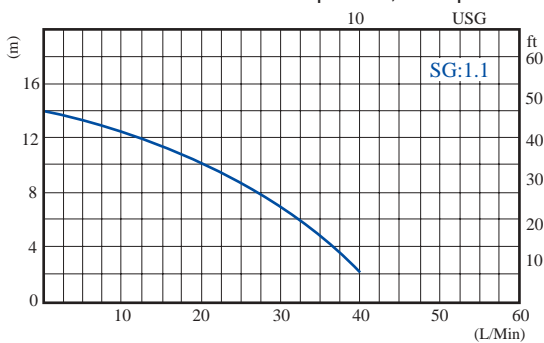

NH-200PS-Z 60Hz Nominal speed 3,300 r.p.m

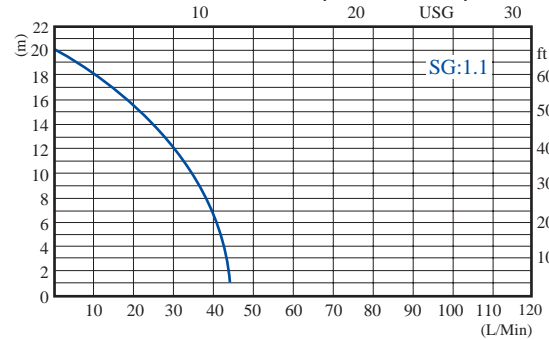

NH-250PS 50Hz Nominal speed 2,700 r.p.m

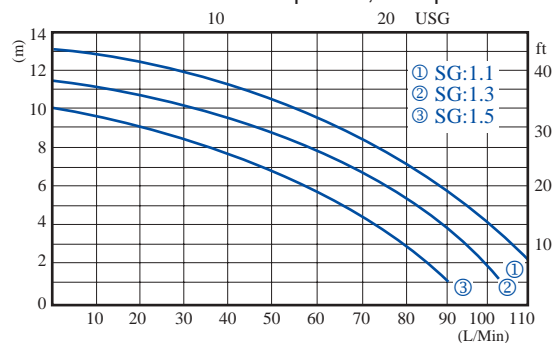

NH-250PS 60Hz Nominal speed 3,350 r.p.m

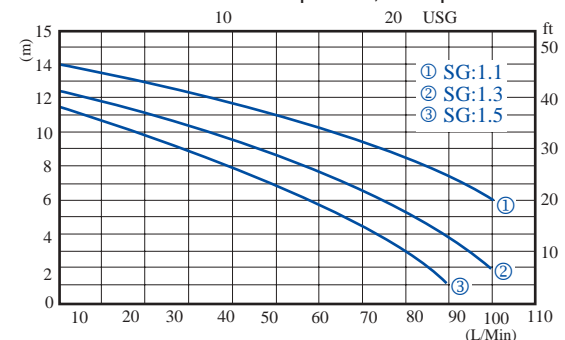

PS-F Series (ETFE)

Magnetic Drive Pumps For Hazardous Chemical Transfer

- ETFE wetted-end material for hazardous chemical transfer.
- 8 models with flow rates up to 120 lit/min.
- Available in hose, threaded or flange connections.



Specification table

Nominal speed 2,700/3,200 r.p.m

Model	Connection method				Performance, M-L/min, 50-60Hz		Motor
	Hose (mm)	Thread (")	Union (A)	Flange (A)	Max total head- max discharge	Specified head- specified discharge	Output x Input (W)
	In x Outlet	In x Outlet	In x Outlet	In x Outlet			
125PS-F	25 x 25	NPT1x1, G1x1	20	25 x 25	3.3-75/4.7-85	2.0-47/2.0-65	65 - 90/130
150PS-F	25 x 25	NPT1x1, G1x1	20	25 x 25	5.6-60/8.2-70	4-30/4-45	90 - 130/170
200PS-Z-F	25 x 25	NPT1x1, G1x1	20	25 x 25	12.5-35/16-37	9-20/8-30	150 - 290
200PS-F	25 x 25	NPT1x1, G1x1	20	25 x 25	10-90/12-110	6.5-50/7.5-70	150 - 290
200PS-F-3	25 x 25	NPT1x1, G1x1	20	25 x 25	10-90/12-110	6.5-50/7.5-70	150 - 290
250PS-F	25 x 25	NPT1x1, G1x1	20	25 x 25	12.5-120/14-120	9-65/9-80	250 - 390
250PS-F-3	25 x 25	NPT1x1, G1x1	20	25 x 25	12.5-120/14-120	9-65/9-80	250 - 390
250PS-F-3E	25 x 25	NPT1x1, G1x1	20	25 x 25	12.5-120/14-120	9-65/9-80	JEM - 0.2kW

Pump performance curve

NH-200PS-F 50Hz Nominal speed 2,500 r.p.m

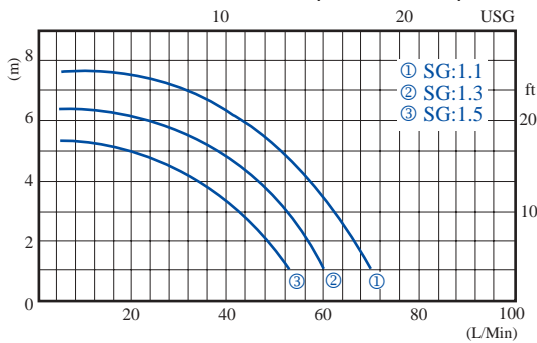

NH-200PS-F 60Hz Nominal speed 3,300 r.p.m

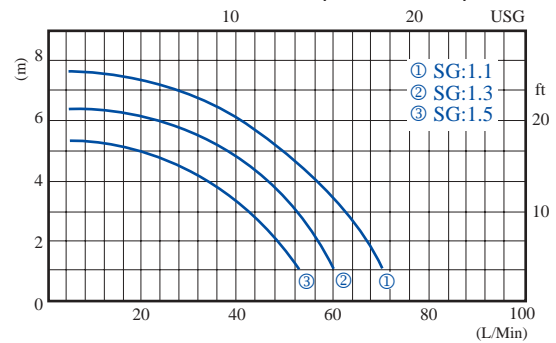

NH-200PS-F-Z 50Hz Nominal speed 2,500 r.p.m

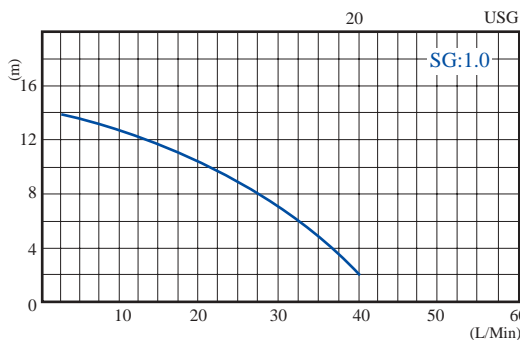

NH-200PS-F-Z 60Hz Nominal speed 3,300 r.p.m

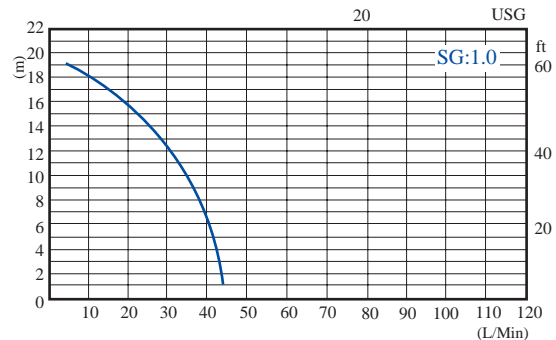

NH-250PS-F 50Hz Nominal speed 2,700 r.p.m

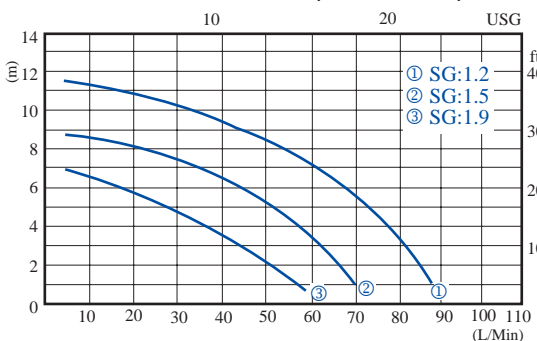

NH-250PS-F 60Hz Nominal speed 3,350 r.p.m

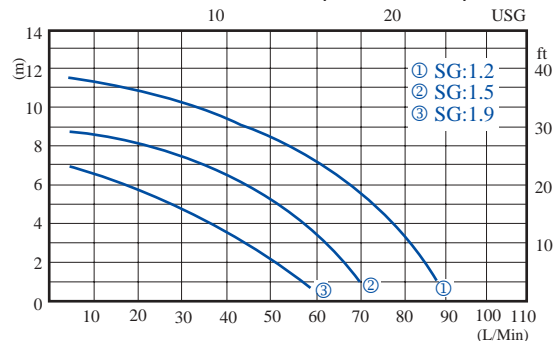

PW Series (PPG)

General Purpose Magnetic Drive Pumps

- PPG wetted-end material.
- 9 models with flow rates up to 1400 lit/min and discharge head of 37m.
- Able to handle many types of chemical and temperature of up to 70 °C.
- Adaptable to IEC Standard motor, 0.37 to 11kw.
- Available in flange connections.



Type indication

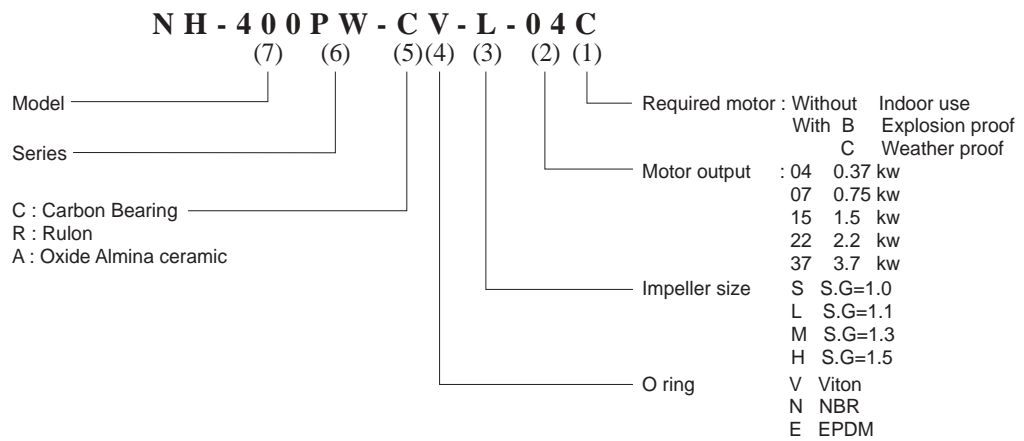

Specification table

Type	Flange size		Pump performance at specified point (M at L/min)			Applicable Motor output (KW)	Net weight (Kg)
	Outlet (mm)	Inlet (mm)	Specific Gravity	50Hz	60Hz		
NH-400PW	40A	40A	1.1	8.3 - 165	6.7 - 160	IEC 0.37kw	16
			1.3	7.0 - 155	7.8 - 140		
			1.5	6.1 - 130	5.9 - 130		
NH-401PW	40A	40A	1.1	12.0 - 240	11.5 - 250	IEC 0.75kw	23
			1.3	9.8 - 185	9.2 - 200		
			1.5	9.1 - 165	7.5 - 200		
NH-402PW	40A	50A	1.1	14.0 - 320	14.0 - 300	IEC 1.5kw	33
			1.3	14.0 - 280	13.9 - 265		
			1.5	12.0 - 280	14.5 - 220		
NH-403PW	40A	50A	1.1	20.0 - 310	19.0 - 280	IEC 2.2kw	37
			1.3	16.0 - 340	17.0 - 280		
			1.5	15.5 - 340	14.7 - 340		
NH-405PW	40A	50A	1.1	23.0 - 390	24.0 - 420	IEC 3.7kw	52
			1.3	21.1 - 400	24.0 - 390		
			1.5	19.0 - 390	20.0 - 390		
NH-655PW	65A	80A	1.1	15.0 - 700	15.5 - 600	IEC 3.7kw	110
			1.3	12.0 - 650	---		
			1.5	10.2 - 570	---		
NH-657PW	65A	80A	1.1	17.5 - 800	18.0 - 750	IEC 5.5kw	120
			1.3	17.6 - 630	16.5 - 630		
			1.5	15.3 - 620	13.3 - 760		
NH-6510PW	65A	80A	1.1	23.4 - 780	23.4 - 800	IEC 7.5kw	130
			1.3	22.7 - 640	19.6 - 770		
			1.5	17.5 - 800	18.1 - 670		
NH-6515PW	65A	80A	1.1	25.5 - 1040	29.5 - 1030	IEC 11.0kw	140
			1.3	25.5 - 1040	31.5 - 650		
			1.5	25.2 - 880	24.6 - 850		

Parts List

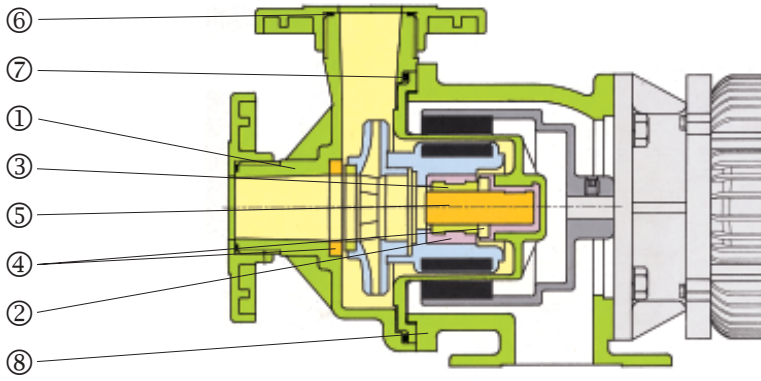

Part name	PW Series				
	CV	RV	AV	CN	AN
1. Casing	PPG				
2. Holder	PPS				
3. Bearing	Carbon	Rulon	Ceramic	Carbon	Ceramic
4. Thrust pad	Ceramic				
5. Spindle	Ceramic				
6. O ring	FKM		NBR		
7. O ring	FKM		NBR		
8. Bracket	Grey cast iron				

PW series performance curve

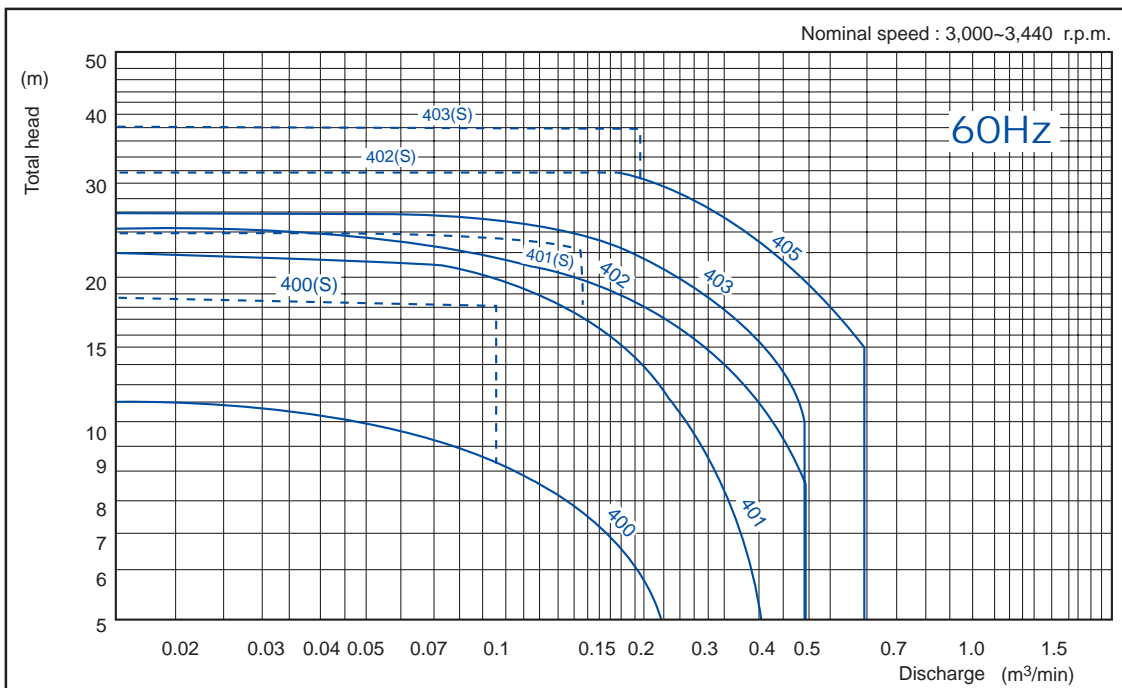
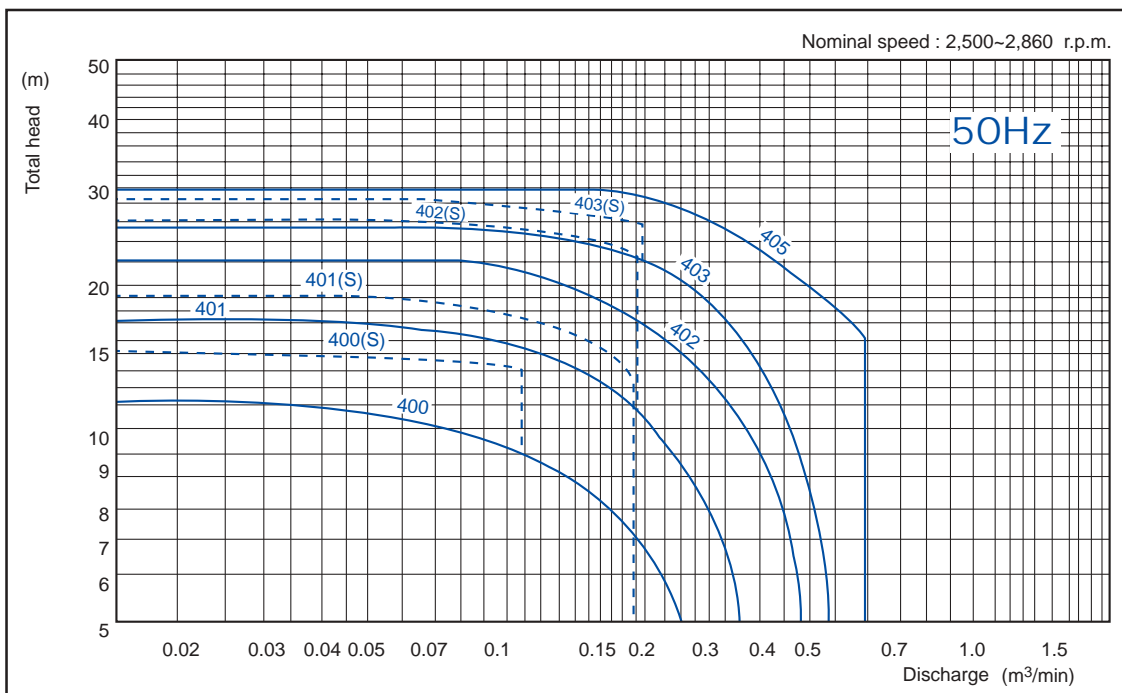

PW-F Series (ETFE)

Magnetic Drive Pumps For Hazardous Chemical Transfer



- ETFE (carbon-fibre reinforced) wetted-end material.
- 9 models with flow rates up to 530 lit/min and discharge head of 42m.
- Able to handle almost all types of chemical and temperature up to 90 °C.
- Adaptable to IEC Standard motor, 0.37 to 11kw.
- Available in flange connections.

Type indication

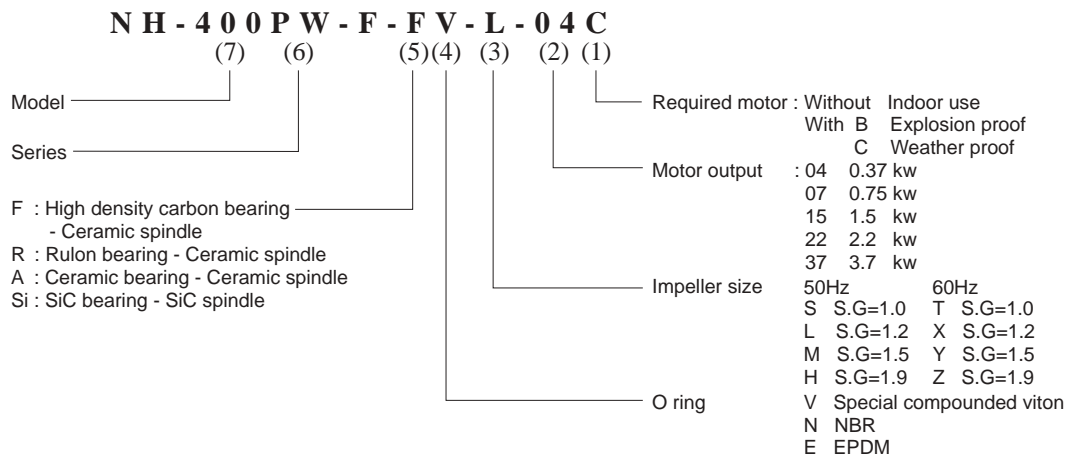

Specification table

Type	Flange size		Pump performance at specified point (M at L/min)			Applicable Motor output (KW)	Net weight (Kg)
	Outlet (mm)	Inlet (mm)	Specific Gravity	50Hz	60Hz		
NH-400PW-F	40A	40A	1.2	7.4 - 135	8.0 - 110	IEC 0.37kw	16
			1.5	6.5 - 135	5.2 - 135		
			1.9	4.7 - 120	3.9 - 120		
NH-401PW-F	40A	40A	1.2	10.0 - 180	9.5 - 180	IEC 0.75kw	23
			1.5	8.5 - 160	8.8 - 160		
			1.9	6.0 - 175	5.2 - 175		
NH-402PW-F	40A	50A	1.2	16.0 - 260	15.5 - 260	IEC 1.5kw	33
			1.5	13.0 - 240	13.5 - 240		
			1.9	10.0 - 280	7.9 - 280		
NH-403PW-F	40A	50A	1.2	17.0 - 330	15.0 - 330	IEC 2.2kw	37
			1.5	15.0 - 310	16.3 - 310		
			1.9	14.0 - 280	13.0 - 280		
NH-405PW-F	40A	50A	1.2	24.5 - 390	24.5 - 390	IEC 3.7kw	52
			1.5	20.5 - 310	20.3 - 350		
			1.9	15.2 - 220	19.3 - 290		
NH-655PW-F	65A	80A	1.2	12.2 - 600	19.8 - 400	IEC 3.7kw	110
			1.5	11.0 - 540	---		
			1.9	---	---		
NH-657PW-F	65A	80A	1.2	17.0 - 700	18.0 - 620	IEC 5.5kw	120
			1.5	15.3 - 625	13.5 - 750		
			1.9	11.3 - 660	---		
NH-6510PW-F	65A	80A	1.2	22.2 - 760	20.7 - 830	IEC 7.5kw	130
			1.5	18.9 - 720	18.0 - 680		
			1.9	15.5 - 660	15.0 - 720		
NH-6515PW-F	65A	80A	1.2	26.8 - 1080	24.0 - 1110	IEC 11.0kw	140
			1.5	26.0 - 815	26.0 - 800		
			1.9	24.1 - 600	20.5 - 835		

Parts List

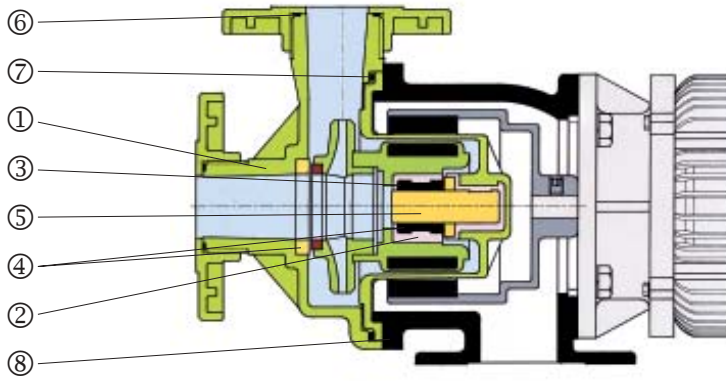

Part name	PW-F Series				
	FV	RV	AV	FN	Si
1. Casing	ETFE				
2. Holder	ETFE				
3. Bearing	H.D. Carbon	Rulon	Ceramic	H.D. Carbon	SiC
4. Thrust pad	Ceramic				SiC
5. Spindle	Ceramic				SiC
6. O ring	FKM		NBR		FKM
7. O ring	FKM		NBR		FKM
8. Bracket	Cast iron				

PW-F series performance curve

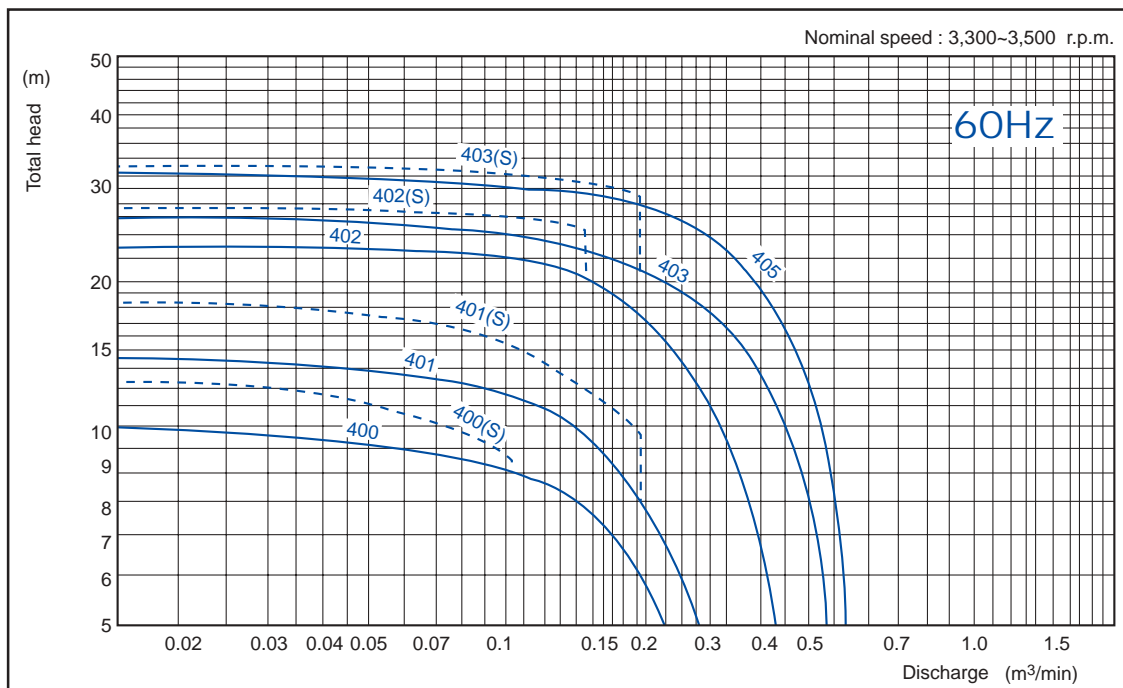
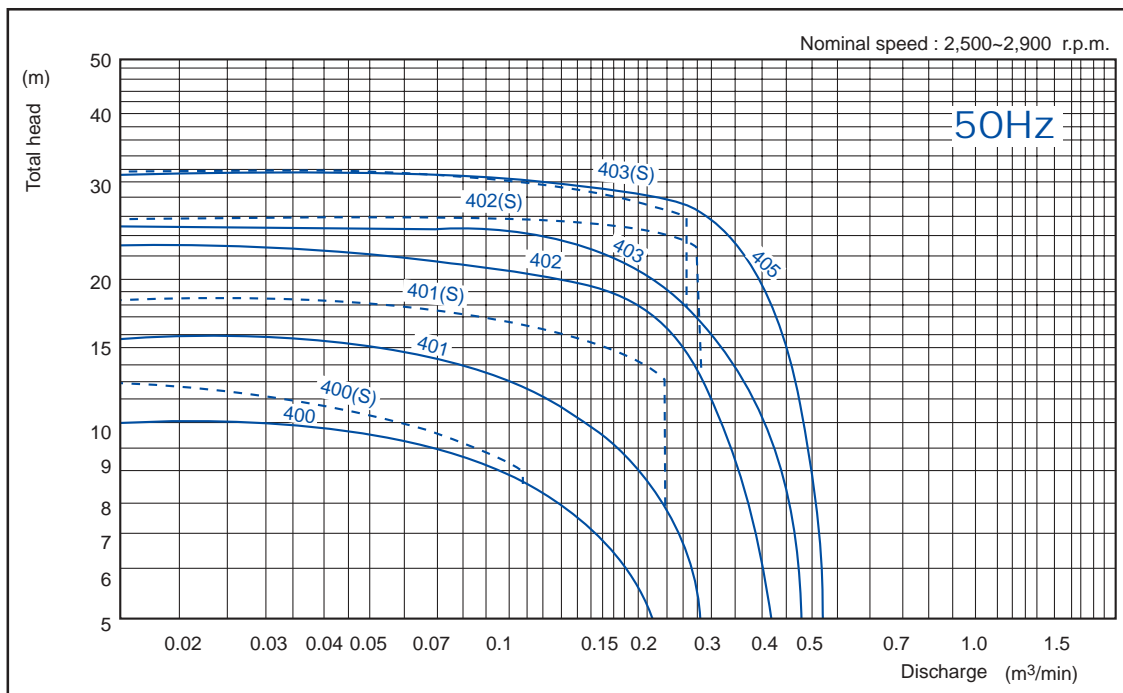

PW-C Series (ETFE-Lined Metal Profile)

Heavy Duty Magnetic Drive Pumps For The Chemical Industry

- ETFE-lined pumps in cast iron exterior and Hastelloy C rear casing cover as reinforcement.
- Robust construction.
- 11 models with flow rates up to 1500 lit/min and discharge head of 42m.
- Can handle practically most chemicals and temperature up to 90 °C.
- Adaptable to IEC Standard motor, 0.37 to 15kw.
- Available in flange connections.

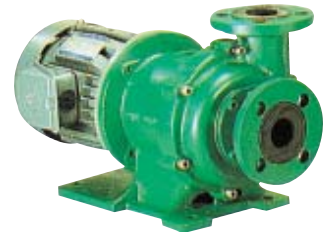

Type indication

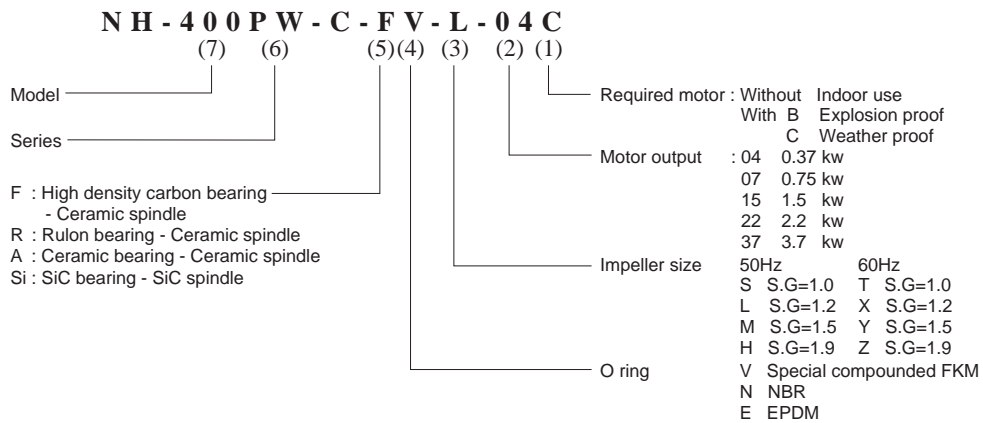

Specification table

Type	Flange size		Pump performance at specified point (M at L/min)			Motor output (KW)	Net weight (Kg)
	Outlet (mm)	Inlet (mm)	Specific Gravity	50Hz	60Hz		
NH-250 PW-C	25	25	1.2	7.0 - 135	6 - 145	0.37	35
			1.5	5.8 - 140	5.5 - 135		
			1.9	4.7 - 115	3.9 - 115		
NH-401 PW-C	40	40	1.2	9.3 - 200	9.5 - 180	0.75	40
			1.5	7.6 - 190	8.7 - 160		
			1.9	7.7 - 170	6.2 - 140		
NH-402 PW-C	40	50	1.2	16 - 260	13.1 - 260	1.5	50
			1.5	14 - 260	13.2 - 260		
			1.9	11 - 240	10.9 - 220		
NH-403 PW-C	40	50	1.2	18 - 320	17.4 - 320	2.2	54
			1.5	15 - 300	13.8 - 320		
			1.9	13.5 - 260	14.5 - 260		
NH-405 PW-C	40	50	1.2	25 - 380	23 - 400	3.7	67
			1.5	22.5 - 350	20.3 - 350		
			1.9	20 - 290	15.2 - 400		
NH-505 PW-C	50	65	1.2	16.7 - 550	16.2 - 560	3.7	80
			1.5	13 - 450	13 - 390		
			1.9	10 - 400	11.7 - 360		
NH-507 PW-C	50	65	1.2	25.7 - 550	27.1 - 500	5.5	104
			1.5	16.3 - 480	15.1 - 500		
			1.9	14.4 - 400	13.7 - 400		
NH-657 PW-C	50	80	1.2	19.2 - 800	20.4 - 800	5.5	130
			1.5	15.4 - 650	14.6 - 700		
			1.9	12.5 - 550	10.8 - 600		
NH-6510 PW-C	50	80	1.2	24.7 - 950	25 - 950	7.5	138
			1.5	20 - 800	19.5 - 720		
			1.9	17 - 710	15.7 - 710		
NH-6515 PW-C	50	80	1.2	32 - 1100	28.8 - 900	11	153
			1.5	24.5 - 900	25 - 900		
			1.9	19.8 - 800	20.5 - 800		
NH-6520 PW-C	50	80	1.2		39 - 1050	15	165
			1.5	---	24 - 1100		
			1.9		24 - 950		

Parts List

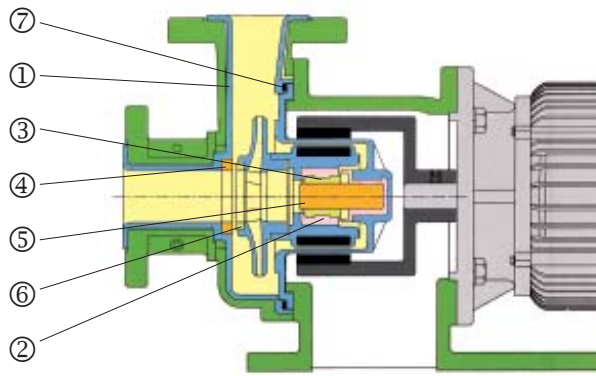

Part name	PW-C Series			
	FV	RV	FN	Si
1. Casing	Carbon fiber reinforced tetra fluorethylene			
2. Holder				
3. Bearing	High density Carbon	PTFE based resin	Ceramic	SiC ceramic
4. Thrust ring	High purity Ceramic			
5. Spindle				
6. Mouth ring	PTFE based resin			
7. O ring	Special Compounded FKM			
8. Cover	Cast iron			

PW-C series performance curve

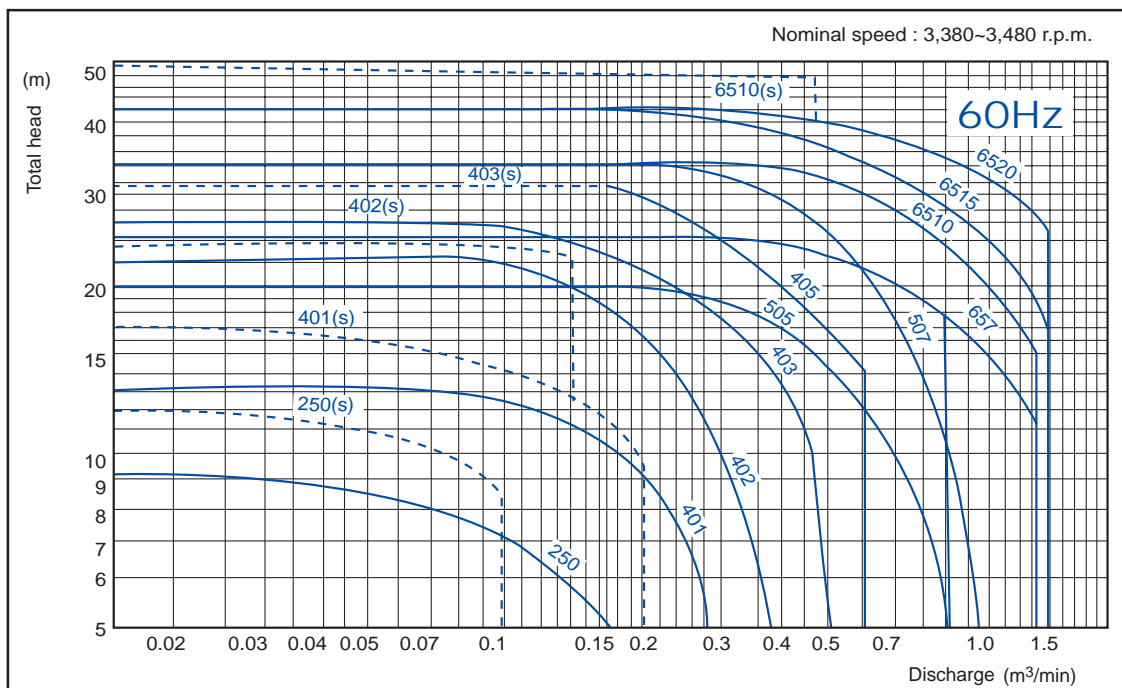
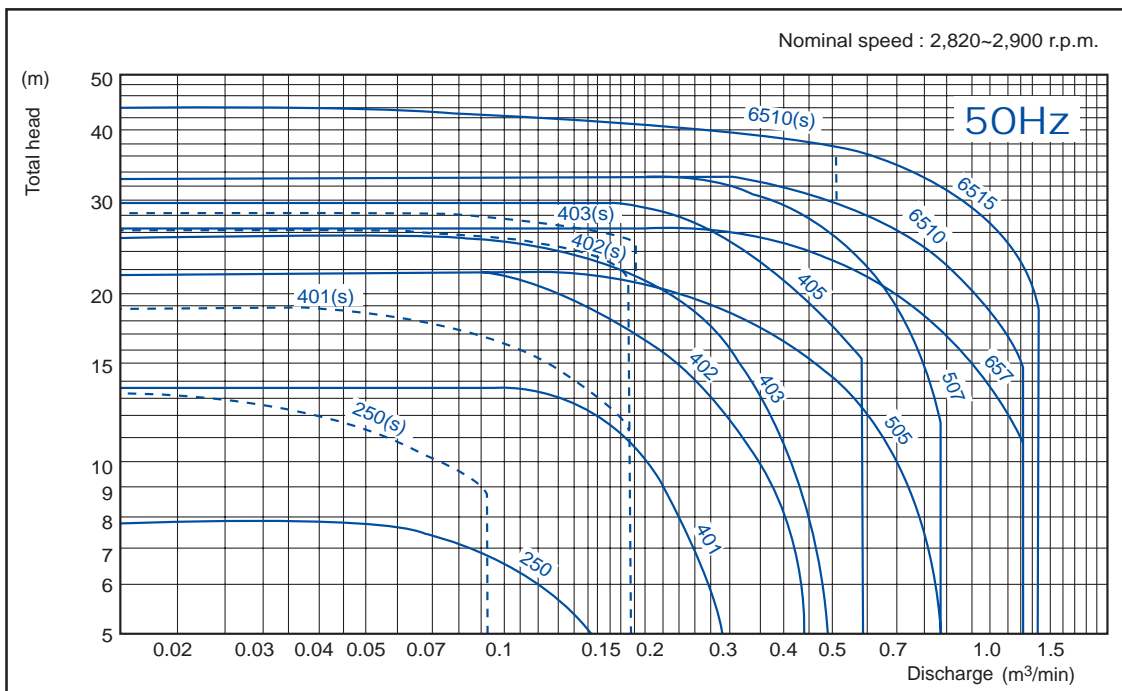

PW / PW-F Series performance curve

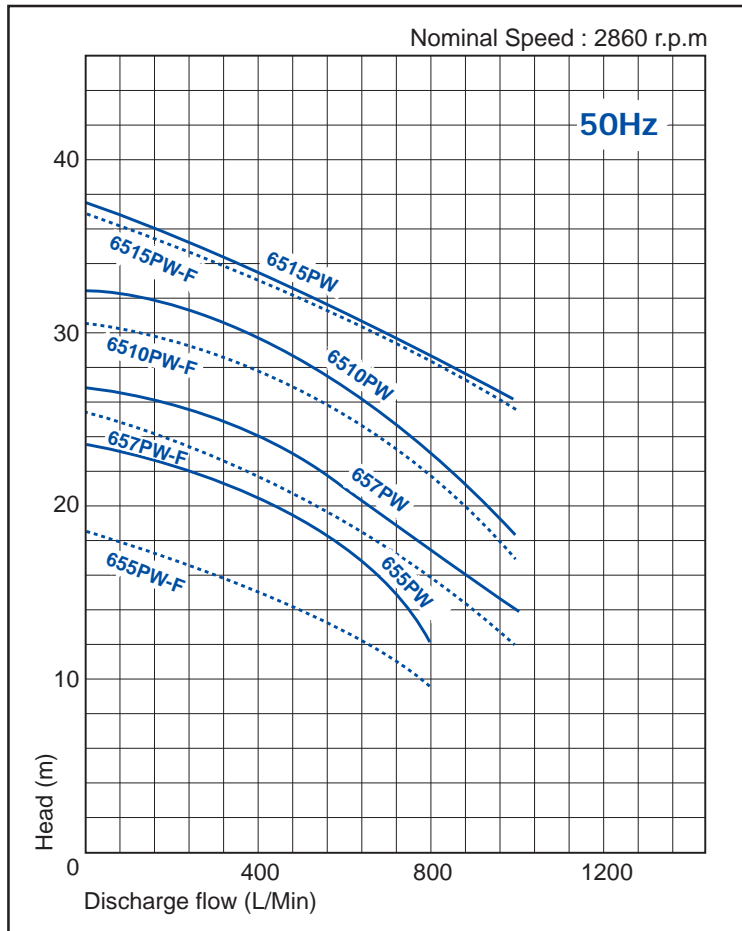

— PW Series SG : 1.1
 PW-F Series SG : 1.2

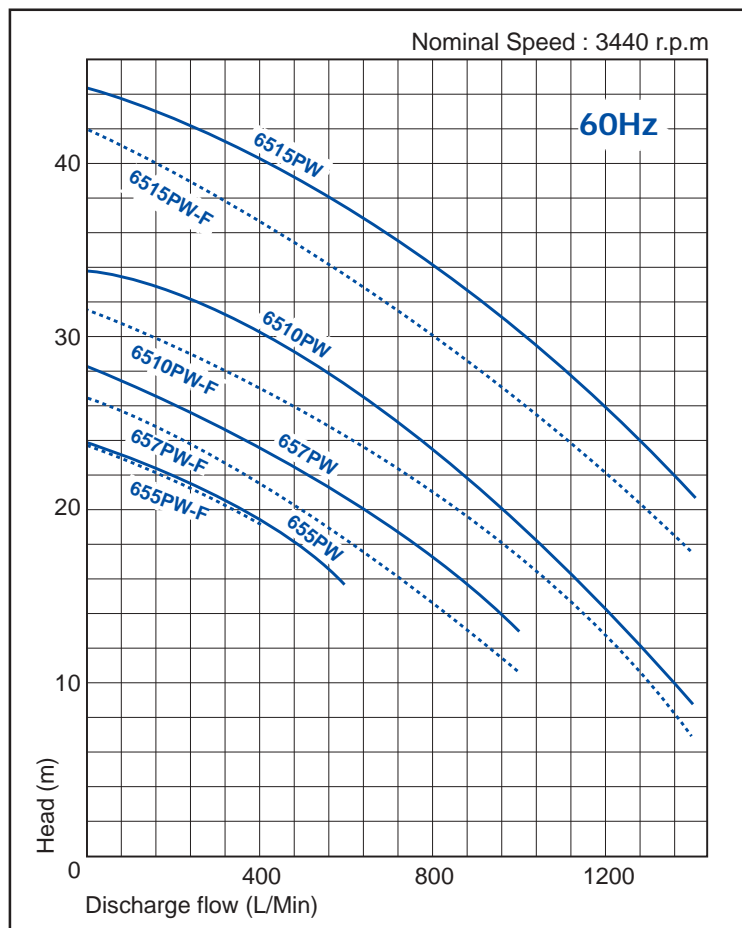

— PW Series SG : 1.1
 PW-F Series SG : 1.2

Installation dimension (for PW / PW-F Series)

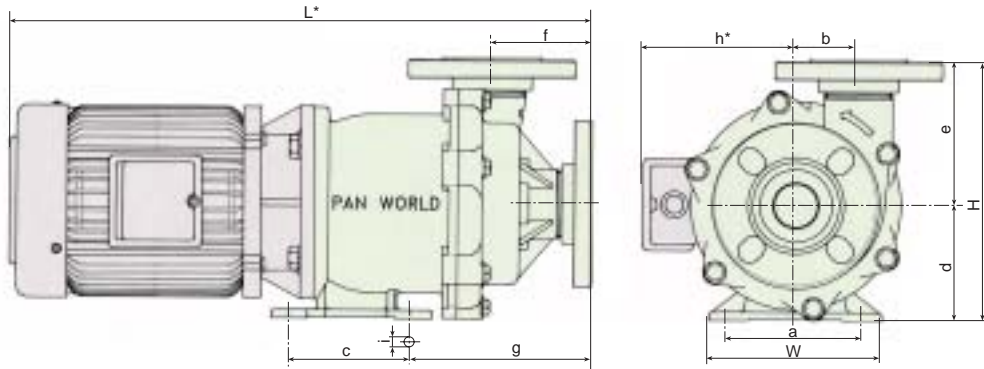

Type	W	H	L*	a	b	c	d	e	f	g	h*	i
NH-400PW / -F	140	216	394	110	51	98	95	121	87	150	125	12
NH-401PW / -F	160	254	488	130	57.5	130	115	139	102.5	184	148	12
NH-402PW / -F	260	255	551	208	65	200	115	140	89	158	158	14
NH-403PW / -F	260	255	591	208	65	200	115	140	89	158	158	14
NH-405PW / -F	260	270	617	208	65	200	130	140	89	158	158	14
NH-655PW / -F	260	360	715	210	85	270	175	185	118	240	-	14
NH-657PW / -F	260	360	746	210	85	270	175	185	118	240	249	14
NH-6510PW / -F	260	360	746	210	85	270	175	185	118	240	249	14
NH-6515PW / -F	350	385	904	300	85	270	200	185	118	240	287	14



- Remarks: 1. This size in the table is shown with JIS motor.
 2. Over all size & construction may be changed without notice.
 3. * Depending on type of motor used.

Installation dimension (for PW-C Series)

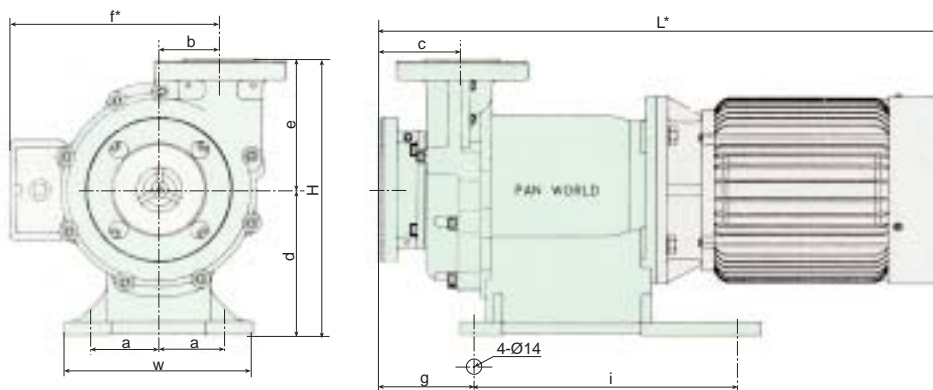

Type	W	H	L*	a	b	c	d	e	f*	g	i
NH-250PW-C	155	237	490	55	51	88	115	122	147	95	146
NH-401PW-C	195	275	528.5	65	57.5	104.5	135	140	152	111	250
NH-402PW-C	200	295	603	70	65	87	155	140	166	106	275
NH-403PW-C	200	295	603	70	65	87	155	140	166	106	275
NH-405PW-C	200	295	675.5	70	65	87	155	140	188	106	275
NH-505PW-C	260	325	720	105	62	110	175	150	188	130	305
NH-507PW-C	260	325	786	105	62	110	175	150	261	130	305
NH-657PW-C	280	360	797.5	110	0	118	175	185	261	193	320
NH-6510PW-C	280	360	797.5	110	0	118	175	185	261	193	320
NH-6515PW-C	350	385	983.5	150	0	118	200	185	281	193	320
NH-6520PW-C	350	385	983.5	150	0	118	200	185	281	193	320



- Remarks: 1. JIS, ISO, NEMA or explosion motor is available.
 2. Over all size & part construction will be changed without notice.
 3. NH-657, 6510, 6515, 6520 are top centre discharge.
 4. * Depending on type of motor used.

PS-SP Series (Glass Fiber reinforced PP)

Compact Magnetic Driven Pump With Self Priming Chamber

- Suitable for application of negative suction lift head
- 8 models with flow rate up to 110 lit/min
- Offering the combination of ceramic bearing & ceramic spindle and combination of SiC as wetted end parts.
- Standard connections available in hose, thread, flange and union.
- 2.2 m suction lift at S.G. 1.0 is available.
- Top mount on to drum can is acceptable for replacement of drum pump.



Pump performance curve

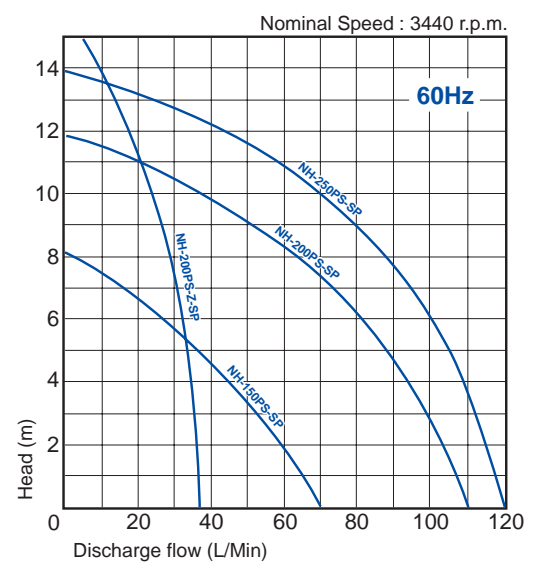
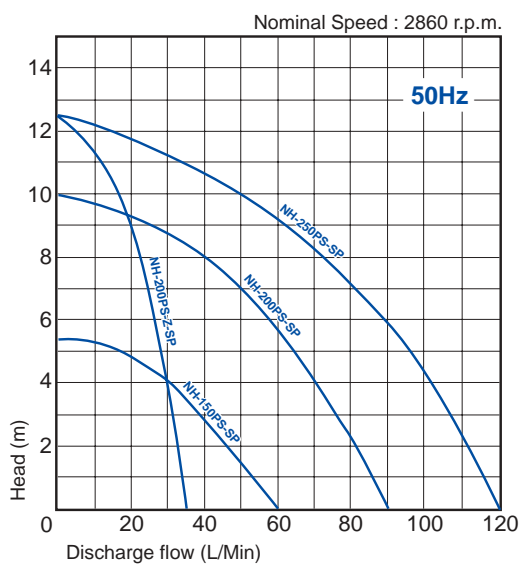

Specification table

Nominal speed 2,500/3,000 r.p.m

Model	Connection method				Performance, M-L/min, 50~60Hz		Max Suction Lift Head (m)	Motor
	Hose (mm)	Thread (")	Union (A)	Flange (A)	Max total head-max discharge	Specified head-specified discharge		
	In x Outlet	In x Outlet	In x Outlet	In x Outlet			Output x Input (W)	
150PS-SP	25 x 25	NPT1x1, G1x1	20	25 x 25	5.6-60/8.2-70	4-30/4-45	2.2	90 - 170
200PS-Z-SP	25 x 25	NPT1x1, G1x1	20	25 x 25	12.5-35/16-37	9-20/8-30	2.2	150 - 290
200PS-SP	25 x 25	NPT1x1, G1x1	20	25 x 25	10-90/12-110	6.5-50/7.5-70	2.2	150 - 290
200PS-SP-3	25 x 25	NPT1x1, G1x1	20	25 x 25	10-90/12-110	6.5-50/7.5-70	2.2	150 - 290
250PS-SP	25 x 25	NPT1x1, G1x1	20	25 x 25	12.5-120/14-120	9-65/9-80	2.2	250 - 390
250PS-SP-3	25 x 25	NPT1x1, G1x1	20	25 x 25	12.5-120/14-120	9-65/9-80	2.2	250 - 390
250PS-SP-3E	25 x 25	NPT1x1, G1x1	20	25 x 25	12.5-120/14-120	9-65/9-80	2.2	JEM - 0.2KW

PW-SP Series

Self-Priming Type Magnetic Drive Pump

- Precision injection part, glass-fibre reinforced PP.
- Advanced design and rugged construction to minimise effect of cavitation or operational error.
- Available in 2 models with max flow rate of 330 lit/min.
- Max suction lift is 1m.
- Adaptable with standard IEC Standard motor.



Specification table

Model	Nominal Flange Size Out x in (mm)	Max total head - max discharge (M-L/Min)	Specified head - specified discharge (M-L/Min)	Allowable suction Lift (m) at S.G.I.O	Applicable IEC motor (KW)
NH-400PW-SP	40 x 40	7.13-90/6.38-90	7.88-202.5	1.0	0.37
NH-401PW-SP	40 x 40	11.03-105/10.65-105	12.75-270/13.5-270	1.0	0.75

Pump performance curve

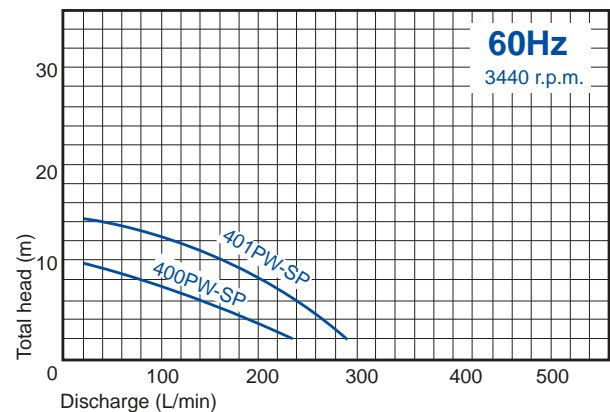
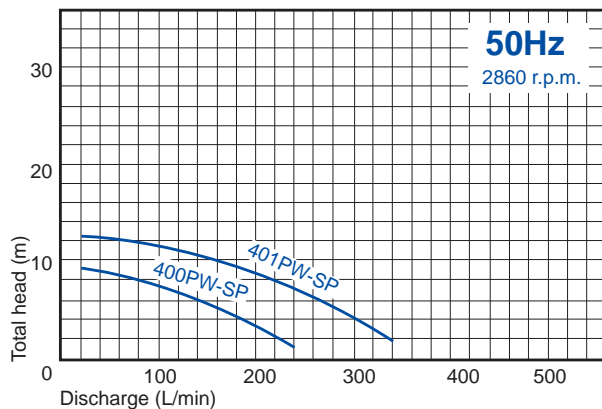

Installation dimension (for PW-SP Series)

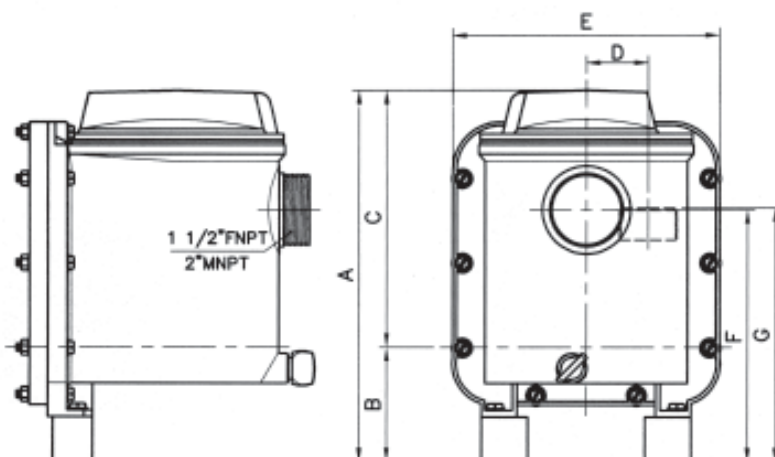

Dimension

	A	B	C	D	E	F	G
SP-400	309	95	214	51	220	212	207
SP-401	329	115	214	57	220	250	227

PA Series

Industrial Mixers

- Available in rubber-lined SUS wetted-end material.
- With universal clamp connection and twin-propeller as standard.
- Suitable for high viscous liquid.
- Mixers available in length from 800 to 1800mm.
- Fitted with original motor, 0.1 to 2.2kw and rotation speed 297rpm.



Specification

Model	Applicable motor	Propeller dia - rod dia x rod length (mm)	Wetted end
NH-10PA	0.1KW, Single phase	160mm-16x800	SUS304
NH-20PA	0.2KW, Single phase	200mm-19x1,000	SUS304
NH-40PA	0.4KW, 3 Phase	250mm-22x1,200	SUS304
NH-75PA	0.75KW, 3 Phase	350mm-28x1,350	SUS304
NH-20PA-V	0.2KW, 3 Phase	200mm-19x1,000	SUS304
NH-40PA-V	0.4KW, 3 Phase	250mm-22x1,200	SUS304
NH-75PA-V	0.75KW, 3 Phase	300mm-28x1,500	SUS304
NH-150PA-V	1.5KW, 3 Phase	350mm-32x1,650	SUS304
NH-220PA-V	2.2KW, 3 Phase	400mm-40x1,800	SUS304
NH-40PA-V-S	0.4KW, 3 Phase	250mm-22x1,200	Rubber lined
NH-75PA-V-S	0.75KW, 3 Phase	300mm-28x1,500	Rubber lined
NH-150PA-V-S	1.5KW, 3 Phase	350mm-32x1,650	Rubber lined
NH-220PA-V-S	2.2KW, 3 Phase	400mm-40x1,800	Rubber lined

PA-S Series

Chemical Stirrers

- Available in PVDF or SUS316 wetted-end material.
- Flange connection for tank top mounting.
- Standard length of 490mm, 690mm and 890mm.
- Driven by 20w/1400rpm TELC motor.



Model identification

NH-PA-S-3-P-4

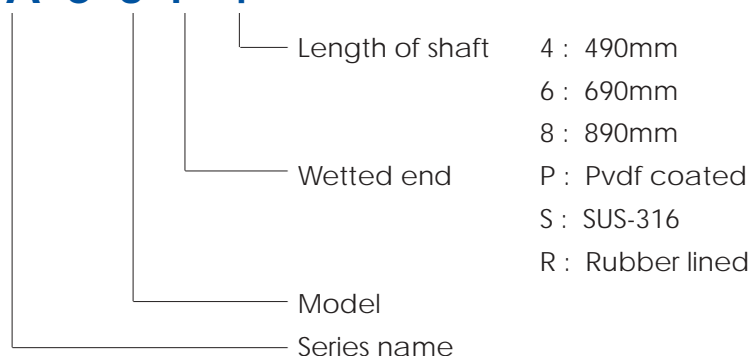

PM-V Series (PPS)

PM-V-F Series (ETFE)

Multistage Magnetic Drive Pumps (Vertical Inline)

- The world first multistage magnetic drive pump in PPS & ETFE material.
- Precision injection part, glass fibre-reinforced PPS and ETFE.
- Pumps available from 3 to 11 stages.
- Flow rates up to 100 lit/min and discharge head to 90m.
- Applicable motors, IEC 0.37kw to 2.2kw.



PM-E Series (PPS)

PM-E-F Series (ETFE)

Multistage Magnetic Drive Pumps (Semi-Submersible End-suction)

- The world first multistage magnetic drive pump in PPS & ETFE material.
- Precision injection part, glass fibre-reinforced PPS and ETFE.
- Pumps available from 3 to 11 stages.
- Flow rates up to 100 lit/min and discharge head to 90m.
- Applicable motors, IEC 0.37kw to 2.2kw.



Expected performance curve

Specification table

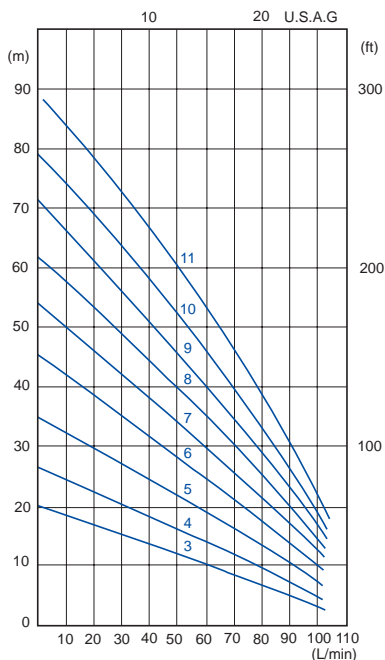

Model	Connection method Out x in (mm)	Max total head - max discharge (M-L/Min)	Applicable IEC motor (KW)
NH-250PM-3	NPT 1" (Thread) 25 x 25 mm (Union) 25 x 25 A (Flange)	20 - 100	0.37
NH-250PM-4		27 - 100	0.37
NH-250PM-5		35.5 - 100	0.75
NH-250PM-6		44.5 - 100	1.5
NH-250PM-7		53 - 100	1.5
NH-250PM-8		62 - 100	1.5
NH-250PM-9		71.5 - 100	1.5
NH-250PM-10		80 - 100	2.2
NH-250PM-11		88 - 100	2.2

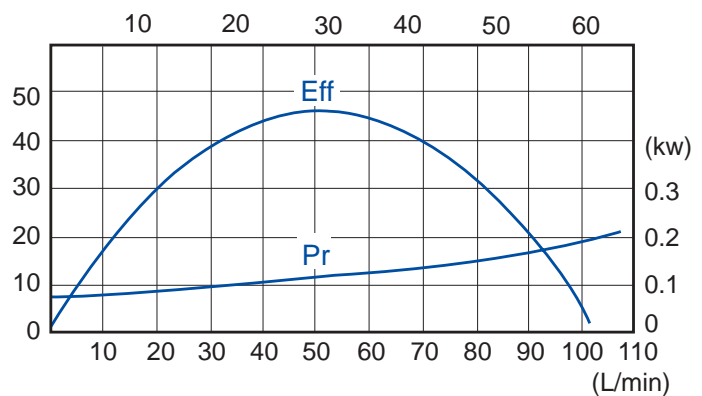
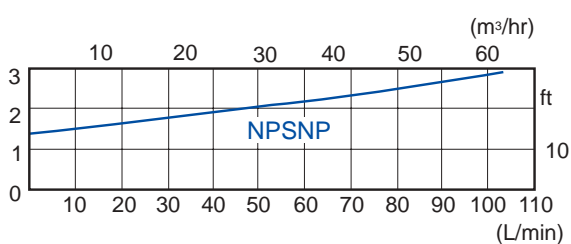

Note: Power requirement / motor is determined by S.G, viscosity and number of impellers.

PF-S & PF-L Series

Mechanical Drive Dosing Pump

- Wetted-end material available in PP, SUS, Teflon or Hastelloy C.
- 15 Models with max flow rates of up to 25 lit/min (50Hz) and discharge pressure to 15 bars.
- Applicable for most chemical dosing.
- Also available in Duplex type.



Combination of construction material

Combination	PC	PS	SS	TC
Pump head	Polypropylene	Polypropylene	SUS 316	PTFE
Ball valve	Ceramic	SUS 316	SUS 316	Ceramic
Valve seat	PVC	SUS 316	SUS 316	PTFE
O ring	Viton®	EPDM	EPDM	Viton®
Diaphragm	PTFE	PTFE	PTFE	PTFE

Accessories

1). Relief valve and Back pressure valve

Connection	Relief valve		Back pressure valve	
	PVC	SUS 316	PVC	SUS 316
15A Flange	NH-SV-1FP	NH-SV-1FS	NH-NV-1PF	NH-NV-1FS
ø5xø9 Hose	NH-SV-1HP	NH-SV-1HS	NH-NV-1HF	NH-NV-1HS
20A Flange	NH-SV-2FP	NH-SV-2FS	NH-NV-2PF	NH-NV-2FS
ø13xø18 Hose	NH-SV-2HP	NH-SV-2HS	NH-NV-2HF	NH-NV-2HS
25A Flange	NH-SV-3FP	NH-SV-3FS	NH-NV-3PF	NH-NV-3FS
40A Flange	NH-SV-4FP	NH-SV-4FS	NH-NV-4PF	NH-NV-4FS
50A Flange	NH-SV-5FP	NH-SV-5FS	NH-NV-5PF	NH-NV-5FS

2). Air chamber

Connection	Model name/Allowable pressure, Bar		Effective capacity
	PVC	SUS 316	
15A Flange	NH-AC-1P/10	NH-AC-1S/15	3L
20A Flange	NH-AC-2P/10	NH-AC-2S/10	5L
25A Flange	NH-AC-2P/5	NH-AC-2S/5	5L
40A Flange	NH-AC-3P/5	NH-AC-3S/5	10L
50A Flange	NH-AC-4P/5	NH-AC-4S/5	20L

3). Strainer/PVC made, Anti-siphon & Filter are optional parts.

Performance table(Reference)

PF-S series

Model	Max. Discharge capacity (l/min)		Max. Discharge Pressure, Bar			Accuracy (%)	Stroke speed (S.P.M)		Connection		Original motor output, kW	Apporx, kg net weight	
	50Hz	60Hz	PP	PTFE	SUS		50Hz	60Hz	Hose	Flange		PP	SUS
PF-S-6S	0.062	0.075	10	10	15	±1.75	48	58	ø5 x ø9	16K, 15A	0.2	14	17
PF-S-12H	0.110	0.130	10	10	15	±1.75	96	116	ø5 x ø9	16K, 15A	0.2	14	17
PF-S-30S	0.300	0.360	10	10	15	±1.75	48	58	ø5 x ø9	16K, 15A	0.2	15	20
PF-S-60H	0.580	0.700	10	10	15	±1.75	96	116	ø5 x ø9	16K, 15A	0.2	15	08
PF-S-120S	1.00	2.00	10	10	10	±1.25	48	58	ø13 x ø18	10K, 20A	0.2	17	24
PF-S-200H	2.00	2.40	8	8	8	±1.25	96	116	ø13 x ø18	10K, 20A	0.2	17	24
PF-S-300S	2.92	3.00	5	5	5	±1.25	48	58	ø13 x ø18	10K, 20A	0.2	19	27
PF-S-400S	3.30	4.00	4	4	4	±1.25	48	58	-----	10K, 25A	0.2	19	27
PF-S-600H	5.83	7.00	3	3	3	±1.25	96	116	-----	10K, 25A	0.2	21	30
PF-S-800H	6.67	8.80	2	2	2	±1.25	96	116	-----	10K, 25A	0.2	22	30

PF-L series

Model	Max. Discharge capacity (l/min)		Max. Discharge Pressure, Bar			Accuracy (%)	Stroke speed (S.P.M)		Connection		Original motor output, kW	Apporx, kg net weight	
	50Hz	60Hz	PP	PTFE	SUS		50Hz	60Hz	Hose	Flange		PP	SUS
PF-L-600H	5.83	7.00	5	5	5	±1.25	96	116	-----	10K, 40A	0.37	38	47
PF-L-800H	6.67	8.80	5	5	5	±1.25	96	116	-----	10K, 40A	0.37	40	48
PF-L-1000S	10.00	12.00	5	5	5	±1.25	48	58	-----	10K, 50A	0.75	77	87
PF-L-2000H	18.00	22.00	5	5	5	±1.25	96	116	-----	10K, 50A	0.75	81	92
PF-L-3000H	25.00	30.00	5	5	5	±1.25	96	116	-----	10K, 50A	1.5	95	118

Note:

1. Flow rates and accuracy shown are at 100% stroke length.
2. Recommended duty is between 25-100% stroke length.
3. Pumps fitted with original motor, either 3-ph or 1-ph.
4. Explosion-proof motors available on request.
5. Performance is based on clean water at 40°C.
6. Duplex type is available for models, PF-6S to PF-800H fitted with 0.2kw motor.

PG Series (ISO-5199 Co-Ni-mo Steel)

Magnetic Drive Pumps



- SUS-316 and SiC wetted-end, magnetic drive pump in compliance with ISO/JIS Standard.
- 14 models with flow rates up to 550 lit/min and discharge head up to 60m.
- Suitable applications include pharmaceutical, reactor, and all types of solvent and alkaline.
- Modular construction of models to minimise parts.
- Applicable motors, IEC, JEM, CNS & NEMA-C, from 2.2kw to 15kw.
- Flanges are to ISO, JSI CNS & ANSI standard.

Specification table

50/60Hz

Model	Flange size Outlet x inlet	Duty point M at L/min	Max point M - L/min	Power requirement at duty point. kW
NH-32-100PG	32 x 50	12/15 at 215	15/19 - 300	2.2 / 4.2
NH-32-120PG	32 x 50	15/20 at 215	20/26 - 300	2.5 / 5.5
NH-32-140PG	32 x 50	20/27 at 215	27/35 - 300	3.1 / 7.3
NH-32-160PG	32 x 50	32/43 at 215	34/46 - 300	4.0 / 9.4
NH-32-180PG	32 x 50	41/50 at 215	43/58 - 300	5.9 / 11
NH-32-200PG	32 x 50	50/66 at 215	54/-- - 300	6.7 / ---
NH-32-210PG	32 x 50	55/71 at 215	60/-- - 300	7.5 / ---
NH-40-100PG	40 x 65	12/15 at 430	16/18 - 550	3.6 / 4.7
NH-40-120PG	40 x 65	15/19 at 430	21/25 - 550	4.4 / 6.5
NH-40-140PG	40 x 65	20/27 at 430	28/35 - 550	5.2 / 8.5
NH-40-160PG	40 x 65	32/42 at 430	35/47 - 550	6.1 / 10.1
NH-40-180PG	40 x 65	40/52 at 430	48/-- - 550	7.6 / ---
NH-40-200PG	40 x 65	50/65 at 430	55/-- - 550	8.6 / ---
NH-40-210PG	40 x 65	55/70 at 430	60/-- - 550	9.4 / ---

Allowable S.G. and required motor output

50/60Hz

Model	S.G:1.0	S.G:1.2	S.G:1.5	S.G:1.9
NH-32-100PG	2.2 / 5.5	3.7 / 5.5	3.7 / 7.5	3.7 / 11
NH-32-120PG	3.7 / 5.5	3.7 / 7.5	5.5 / 11	5.5 / 11
NH-32-140PG	3.7 / 7.5	3.7 / 11	5.5 / 11	7.5 / 11
NH-32-160PG	5.5 / 11	5.5 / 11	7.5 / 11	7.5 / *15
NH-32-180PG	7.5 / 11	7.5 / *15	11 / *15	*11 / ---
NH-32-200PG	7.5 / ---	7.5 / ---	11 / ---	--- / ---
NH-32-210PG	7.5 / ---	11 / ---	*11 / ---	--- / ---
NH-40-100PG	3.7 / 5.5	5.5 / 7.5	5.5 / 7.5	7.5 / 11
NH-40-120PG	5.5 / 7.5	5.5 / 11	7.5 / 11	11 / 11
NH-40-140PG	7.5 / 11	7.5 / 11	7.5 / 11	11 / *15
NH-40-160PG	7.5 / 11	7.5 / 11	7.5 / *15	*11 / ---
NH-40-180PG	11 / *15	11 / *15	*11 / ---	--- / ---
NH-40-200PG	11 / ---	11 / ---	--- / ---	--- / ---
NH-40-210PG	11 / ---	*11 / ---	--- / ---	--- / ---

Note: Pump mode with * mark requires trimming impeller diameter according to specific gravity, viscosity and applicable motor.

--- means that operation is not available.

Pump performance curve

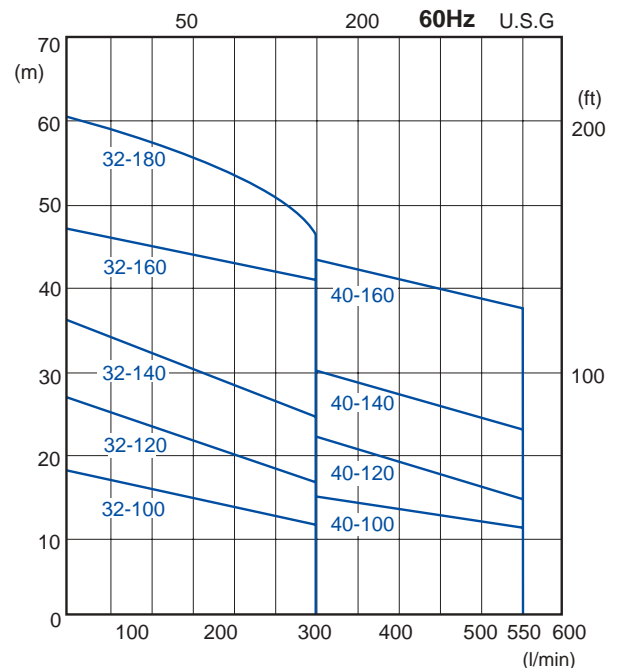
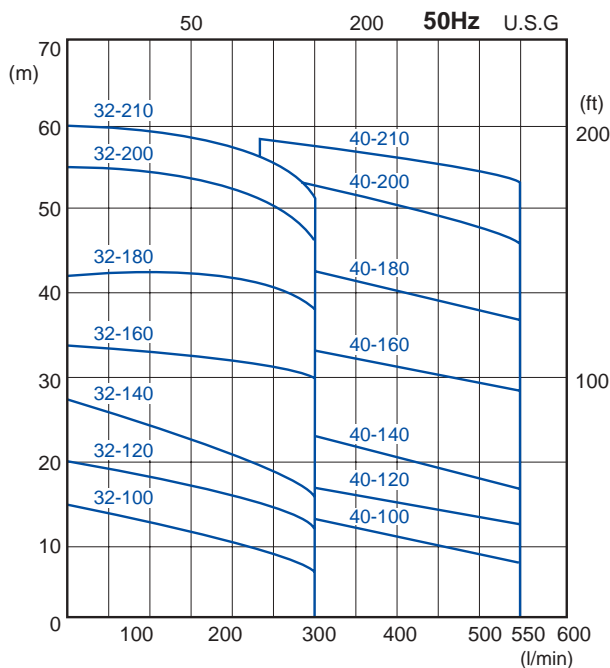

PW-XJ Series (ETFE-Lined Metal Profile)

ISO Standard Magnetic Drive Pumps for the Chemical Industry

- ETFE-lined pumps in cast iron exterior and Hastelloy C rear casing cover as reinforcement.
- Robust construction.
- 5 models with flow rates up to 600 lit/min and discharge head of 72m.
- Can handle practically most chemicals and temperature up to 90 °C.
- Adaptable to IEC, JIS, CNS & NEMA-C Standard motor, 5.5 to 11kw.
- Flanges are to ISO-16 Bar standard.



Specification table

Type	Flange size Outlet x inlet	Duty point 50/60Hz	Max point 50/60Hz	Power kW requirement
		M at L/min	M - L/min	
NH-40-140PW-XJ	ISO-16Bar 40A x 65A	20 at 417 / 31 at 417	25-600/36-600	3.5/5.0
-160PW-XJ		29 at 417 / 44 at 417	34-600/48-600	4.9/7.5
-180PW-XJ		40 at 417 / 60 at 417	44-600/63-600	7.5/11.0
-200PW-XJ		51 at 417 / 75 at 417	55-600/77-600	9.3/13.5
-210PW-XJ		53 at 417 / ---	60-600/ ---	10.5/----

Allowable S.G. and required motor output

Type	S.G:1.0	S.G:1.2	S.G:1.5	S.G:1.9
NH-40-140PW-XJ- □ □ - □ -55- □	5.5 kW	5.5 kW	7.5 kW	11 kW
NH-40-160PW-XJ- □ □ - □ -75- □	7.5 kW	7.5 kW	11 kW	*11 kW
NH-40-180PW-XJ- □ □ - □ -75- □	7.5 kW	11 kW	11 kW	*11 kW
NH-40-200PW-XJ- □ □ - □ -110- □	11 kW	11 kW	*11 kW	*11 kW
NH-40-210PW-XJ- □ □ - □ -110- □	11 kW	11 kW	*11 kW	*11 kW

Note: 1. Pump mode with * mark requires trimming impeller diameter according to specific gravity, viscosity and applicable motor.

2. In case of pump performance curve at 60Hz according each specific, diameter of impeller should be trimmed.

Pump performance curve

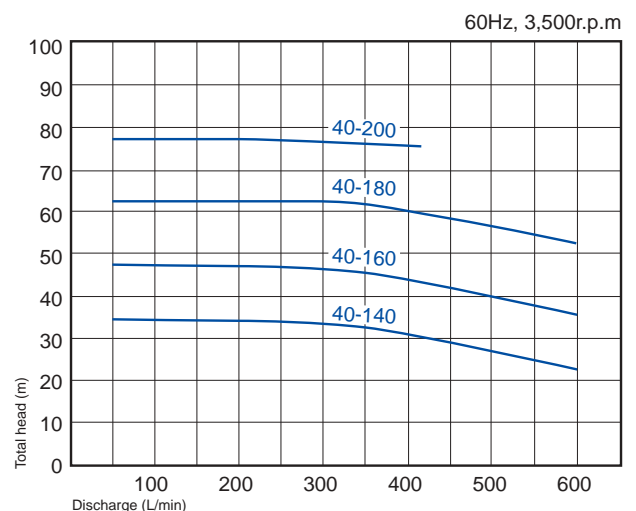
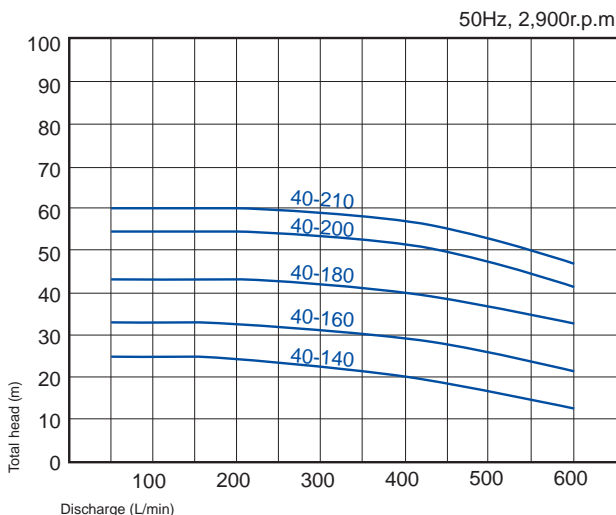

New Product

PV Series

Vertical Sump Pump-For On-Tank Installation

- Vertical Sump Pump in FRPP material.
- Precision injection part.
- Available in 11 models with capacity of up to 1050 lit/min and discharge head of 38m.
- Applicable motors are from 0.37kW to 7.5kW.
- Pump Connections-JIS, CNS, ISO, & ANSI.
- Applications: Printed Circuit Board Machine, Plating Machine, Etching Machine & Filtration Unit.



Pump performance curve

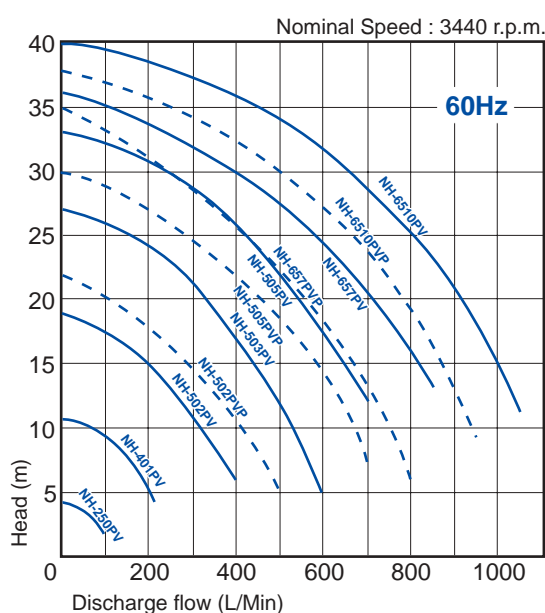
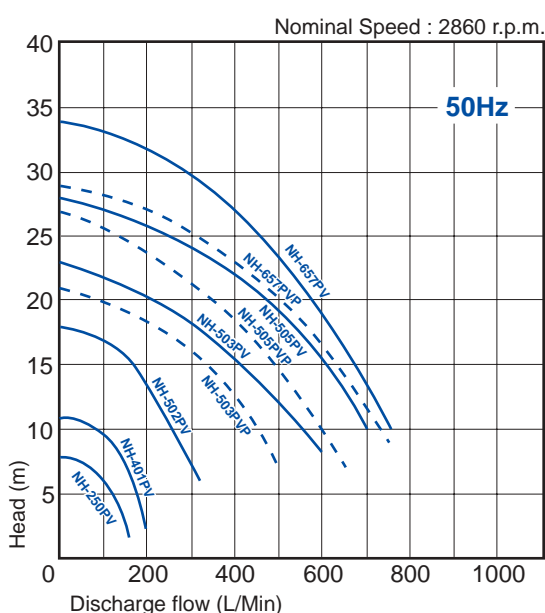

Specification table

Model	Flange Size	Performance, M-L/min, 50~60Hz			Applicable motor output (kW)
	In x Outlet (mm)	Specific Gravity	Max total head-max discharge	Specified head-specified discharge	
NH-250PV	25 x 25	1.1	8-160/4.5-100	6-100/3.1-70	0.37kW
NH-401PV	40 x 50	1.1	11-200/11-210	8-140/8.5-130	0.75kW
NH-502PV	50A x 65A	1.1	18-320/19-400	12-230/12-280	1.5kW
NH-503PV	50A x 65A	1.1	23-600/27-600	14-450/16-420	2.2kW
NH-505PV	50A x 65A	1.1	28-700/33-700	21-450/23-470	3.7kW
NH-657PV	65A x 80A	1.1	34-750/36-850	25-460/26-550	5.5kW
NH-6510PV	65A x 80A	1.1	-----/40-1050	-----/28.5-700	7.5kW
NH-503PVP	50A x 65A	1.4	21-500/22-500	16-300/16-250	2.2kW
NH-505PVP	50A x 65A	1.4	27-650/30-700	20-350/18-540	3.7kW
NH-657PVP	65A x 80A	1.4	29-750/35-800	21-470/21-530	5.5kW
NH-6510PVP	65A x 80A	1.4	-----/38-950	-----/27-600	7.5kW

Installation dimension (for PV / PVP Series)

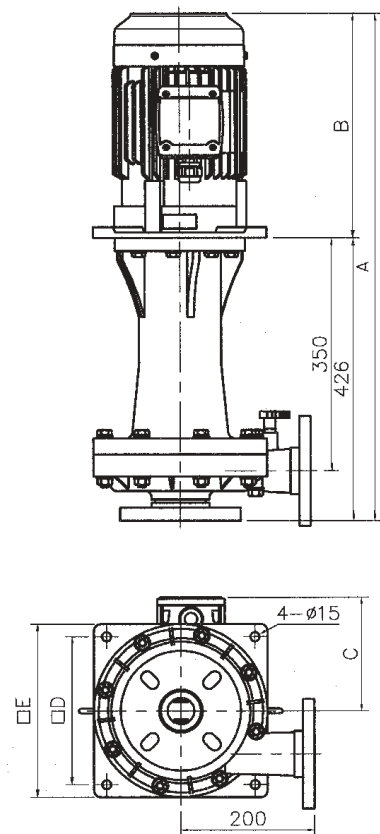
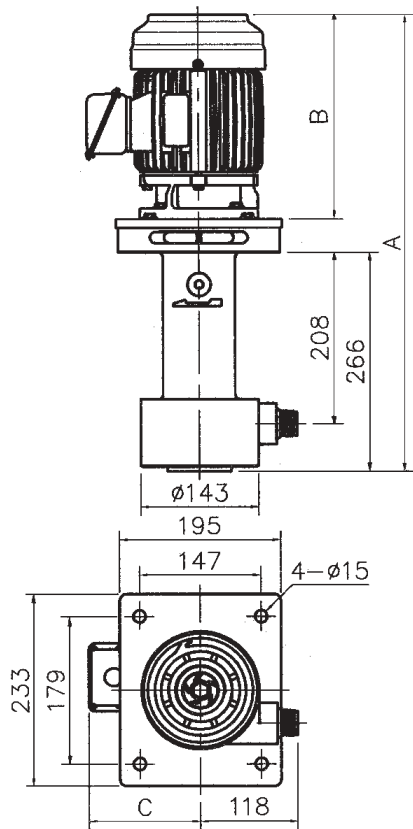

MODEL	A	B	C
NH-250PV	554	248	135
NH-401PV	540	244	145

MODEL	A	B	C	D	E
NH-502PV	763	337	170	222	260
NH-503PV	763	337	170	222	260
NH-505PV	800	375	185	222	260
NH-657PV	855	430	245	300	352
NH-6510PV	855	430	245	300	352

Type indication

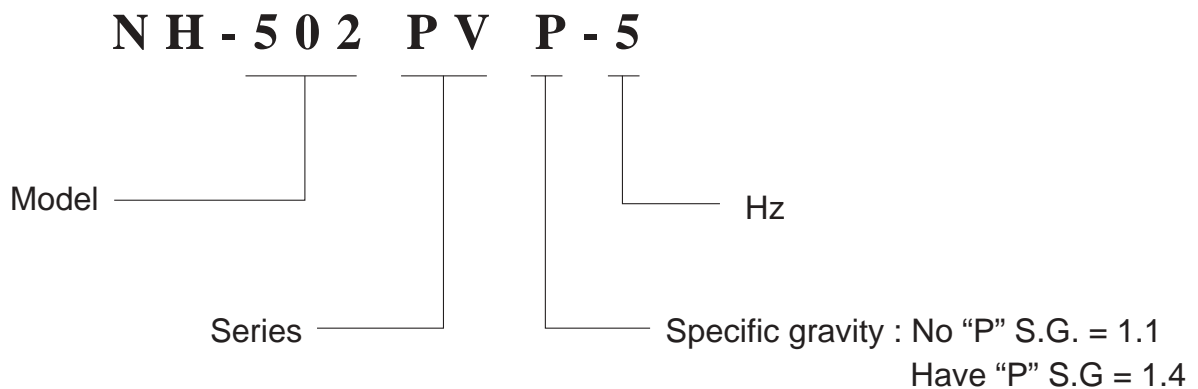

New Product

PW-V Series

Magnetic Drive Vertical Sump Pump - For On-Tank Installation

- The world first Magnetic-Drive Vertical Sump Pump in PPG material.
- Precision injection part.
- Available in 7 models with capacity of up to 900 lit/min and discharge head of 42m.
- Applicable motors are from 1.5kw to 11kw.
- Pump Connections-JIS, CNS, ISO & ANSI.
- Applications: Printed Circuit Board Machine, Plating Machine, Etching Machine & Filtration Unit.



Pump performance curve

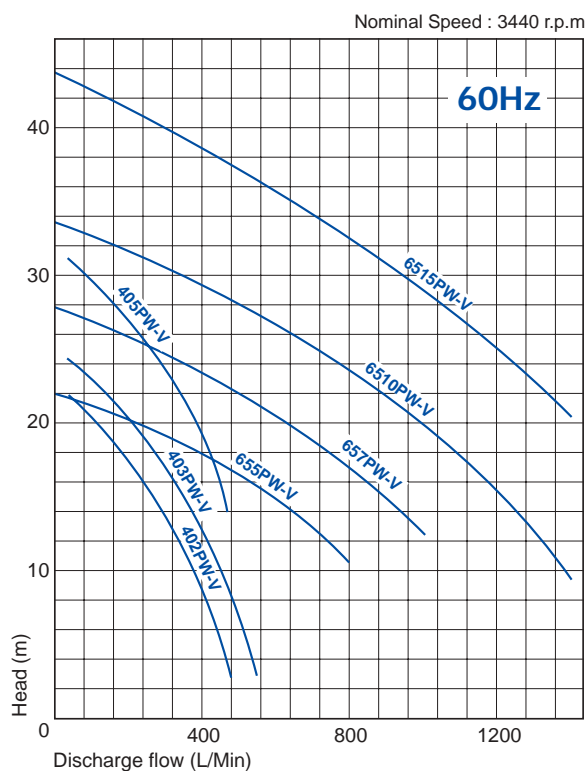
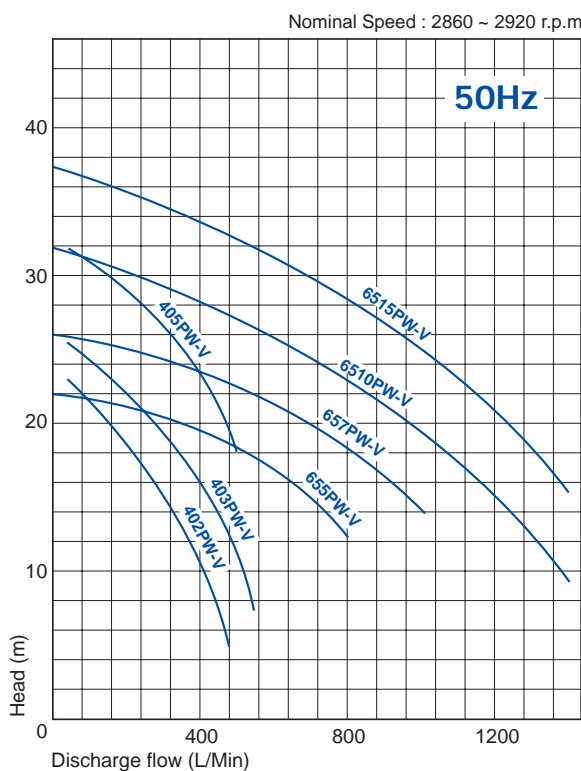

Specification table

Model	Connection		Performance, M-L/min, 50-60Hz		Applicable motor (KW)
	Nominal Flange Size Out x in (A)	Thread connection (inch")	Max total head - max discharge (M-L/Min)	Specified head - specified discharge (M at L/Min)	
NH-402PW-V	50 x 65	2 x 2.5	23 - 480	14 at 320	1.5
NH-403PW-V	50 x 65	2 x 2.5	26 - 530	20 at 300	2.2
NH-405PW-V	50 x 65	2 x 2.5	31.8 - 510	14 at 380	3.7
NH-655PW-V	65 x 80	2.5 x 3	22 - 800	14 at 700	3.7
NH-657PW-V	65 x 80	2.5 x 3	26 - 1000	19 at 720	5.5
NH-6510PW-V	65 x 80	2.5 x 3	32 - 1400	22.5 at 800	7.5
NH-6515PW-V	65 x 80	2.5 x 3	37 - 1400	25 at 1050	11

PR Series

Pump for Aquarium Fountain



PR-600
PR-900



PR-600F
PR-900F



PR-2000



PR-2000F

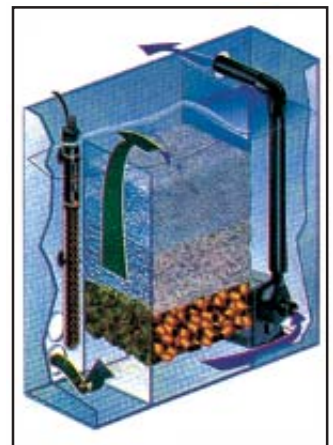

▲ Biological Filter

▼ Water Movement

High performance pump-for marine and fresh water tanks.
One-piece rotor assembly-suitable for biological and wet-and-dry (trickle) filters and for water circulation, fountain.

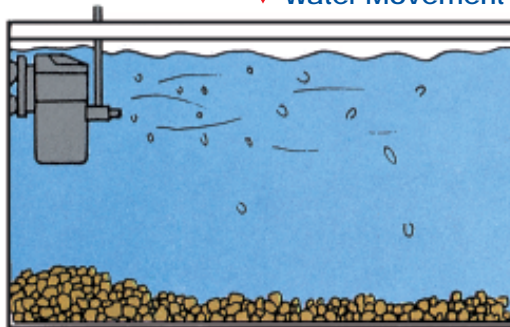

Model	Max flow	Max T.D.H.	Input (W)
PR-600	600 L/Hr	0.5 m	8
PR-900	900 L/Hr	0.8 m	10
PR-2000	2000 L/Hr	1.8 m	32
PR-600F	600 L/Hr	0.5 m	8
PR-900F	900 L/Hr	0.8 m	10
PR-2000F	2000 L/Hr	1.8 m	32

Item No.	Description
01	Base
02	Motor
04	Impeller/Rotor Assembly
05	Impeller Cover
09	Filter Foam
10	Strainer

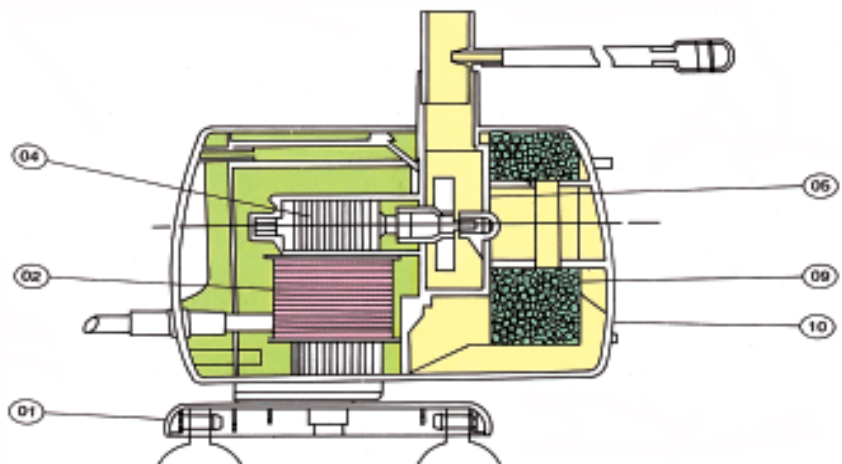

PH Series (Glass Fiber reinforced PPS)

0.75-2.2kW, Max spec. point: T.D.H. 60 m at 100L/min

Single Stage And Multi Stage Compact Magnetic Driven Pump

- Pumps available up to 2 stages.
- Precision injection part.
- Flow rate up to 100 L/min and discharge head to 60m.
- Suitable for P.C.B. machine, Filtration, Etching Machine.
- Applicable IEC motor IEC 0.75kW to 2.2kW (Also NEMA-C face motor is available).
- Can handle most chemicals up to 90°C.
- Available in G-thread and NPT thread.



Type indication

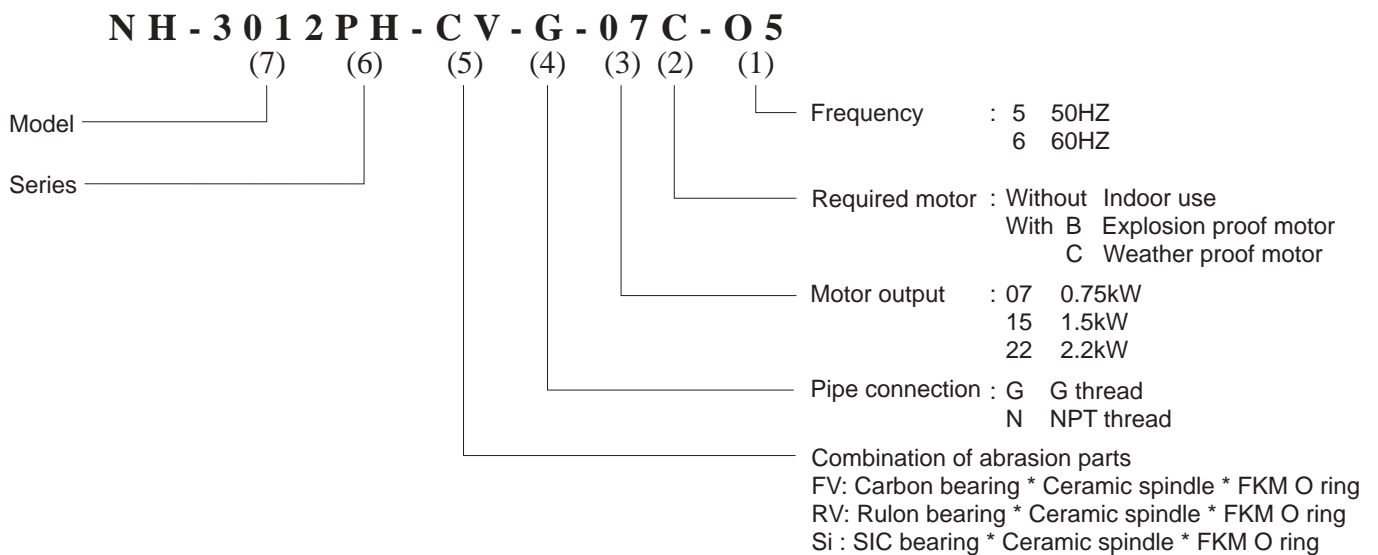

Specification table

Model	Pipe Connection	Max T.D.H.-Max flow	Speci. point	Required motor output
NH-3212PH	25A * 25A	22m - 120L/min	20m at 100L/min	0.75kW
NH-3013PH	25A * 25A	33m - 120L/min	30m at 100L/min	1.5kW
NH-3024PH	25A * 25A	43m - 120L/min	40m at 100L/min	1.5kW
NH-3026PH	25A * 25A	65m - 120L/min	60m at 100L/min	2.2kW

Note: Pump performances of 50Hz and 60Hz are totally same performances.

Pump performance curve

T.D.H.

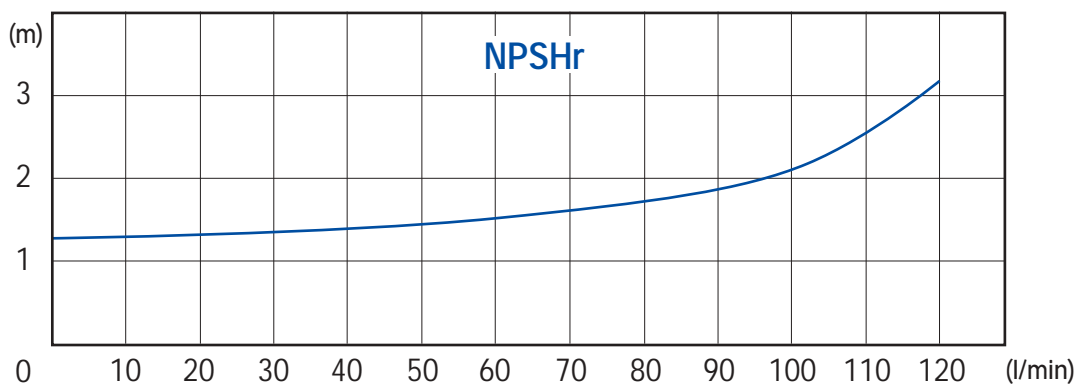
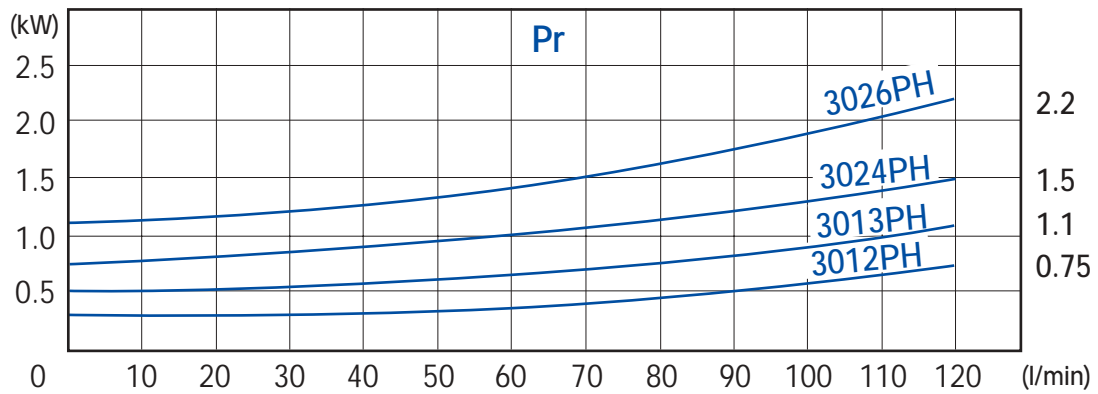
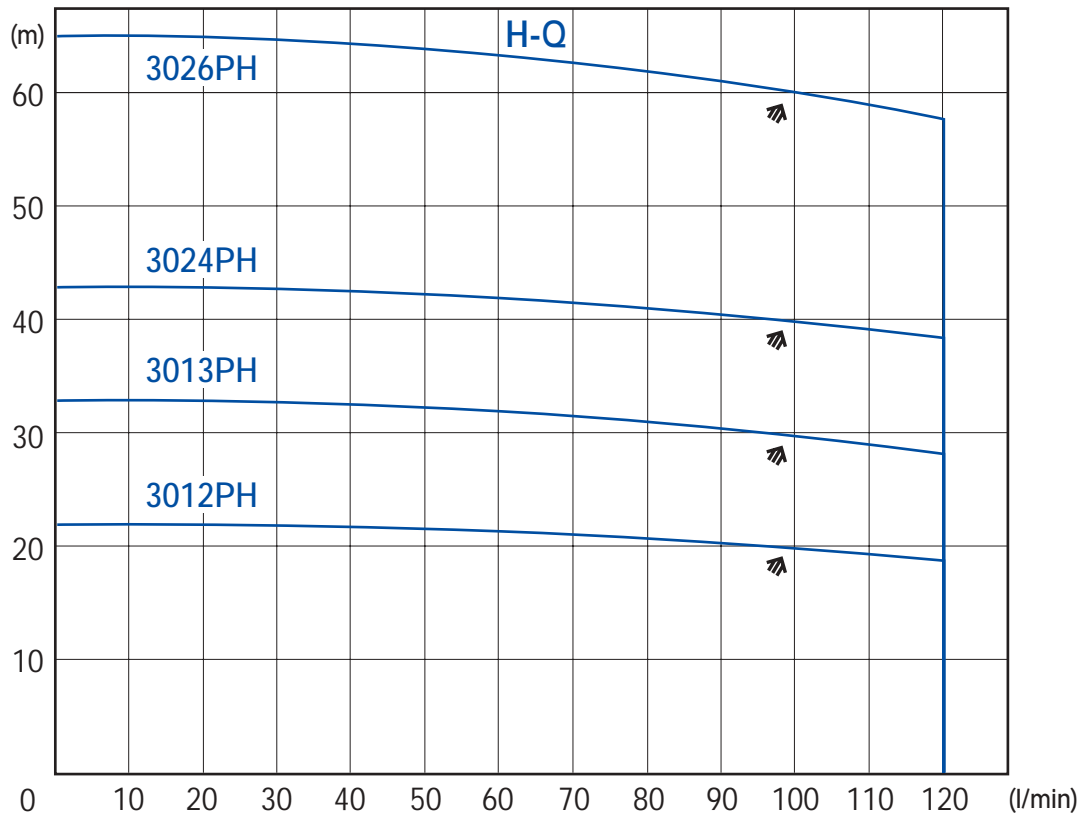

PD Series

Pan World Dry Running Protector

- Compact design.
- Two integral current transformers.
- Wide range current adjustment.
- Definite trip time characteristic.
- Manual (instantaneous) / Electric (remote) reset.
- Easy maintenance.



PT Series

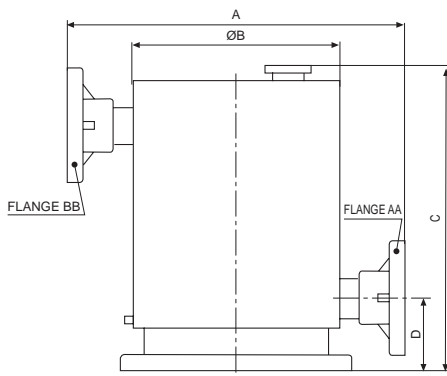

Dimension

	A	B	C	D	E	F	G	AA	BB
PT-400	440	270	400	95	215	300	ø11	40A	40A
PT-401	440	270	470	115	215	300	ø11	40A	40A
PT-402	440	270	550	115	215	300	ø11	50A	50A

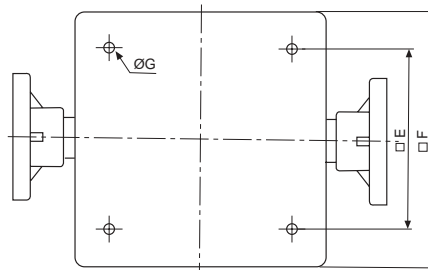

NOTE:

- 1) Material hard PVC.
- 2) Allowable self priming static head 3m at S.G./1.0.
- 3) Allowable overall suction pipe length 4m.

Specification table

		PT-05	PT-30	PT-60
Current range		0.5-6A	3.0-20A	5.0-60A
Trip time setting		0.2 - 30 sec.		
Power supply	024	DC 24V		
	110	Single phase 110V AC		
	220	Single phase 220V AC		
Output relay		3A 250V AC		

Type indication

NH - PT - 05 - 110

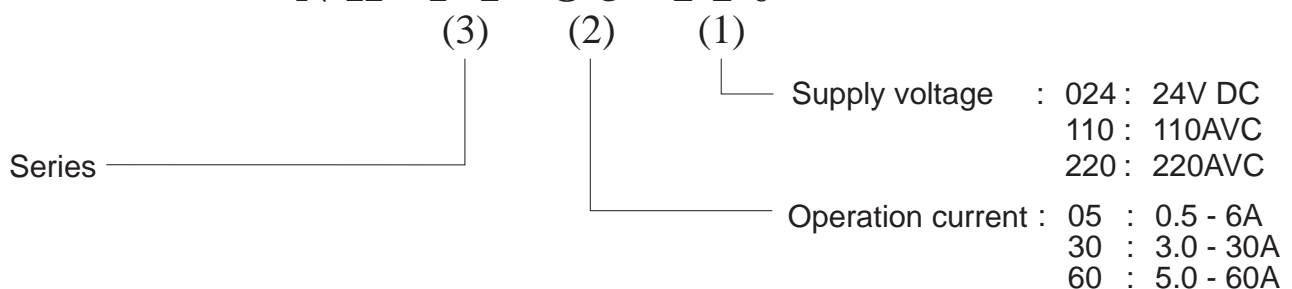



PAN WORLD GROUP OF COMPANIES

PAN WORLD CO LTD (JAPAN)

TPW HONG YUAN CO LTD (TAIWAN)

PAN WORLD PUMPS ASIA PACIFIC PTE LTD (SINGAPORE)

VHP CO LTD (PHILIPPINES)

TECH ISLAND INC (TAIWAN)

HUMAN-TECH PW CO LTD (KOREA)

PAN WORLD CO LTD (USA)



PAN WORLD CO LTD

1097-18, YAMADA-CHO MITSUKAIDO,
IBARAKIKEN, JAPAN
TEL : (81) 2972 3 5560
FAX : (81) 2972 3 5561
Email: message@panworld-jp.com
[http: www.panworld.jp.com](http://www.panworld.jp.com)

TECHNIQUES DES FLUIDES

10 Rue Jean Poulmarch, bât. 3 ☐
Z.I. du Val d'Argent - Argenteuil ☐
Tél.: 01.34.11.13.73 ☐
Fax: 01.34.11.96.35 ☐
www.techniquesfluides.fr ☐
tdf@techniquesfluides.fr

Specifications are subjected to changes without prior notice.