

TECHNIQUES DES FLUIDES

10 Rue Jean Poulmarch, bat. 3
 Z.I. Du Val d'Argent
 95100 Argenteuil
 Tel. : 01.34.11.13.73 / Fax : 01.34.11.96.35

E-mail : tdf@techniquesfluides.fr
 Site web : www.techniquesfluides.fr



MODEL P4 PLASTIC PUMP

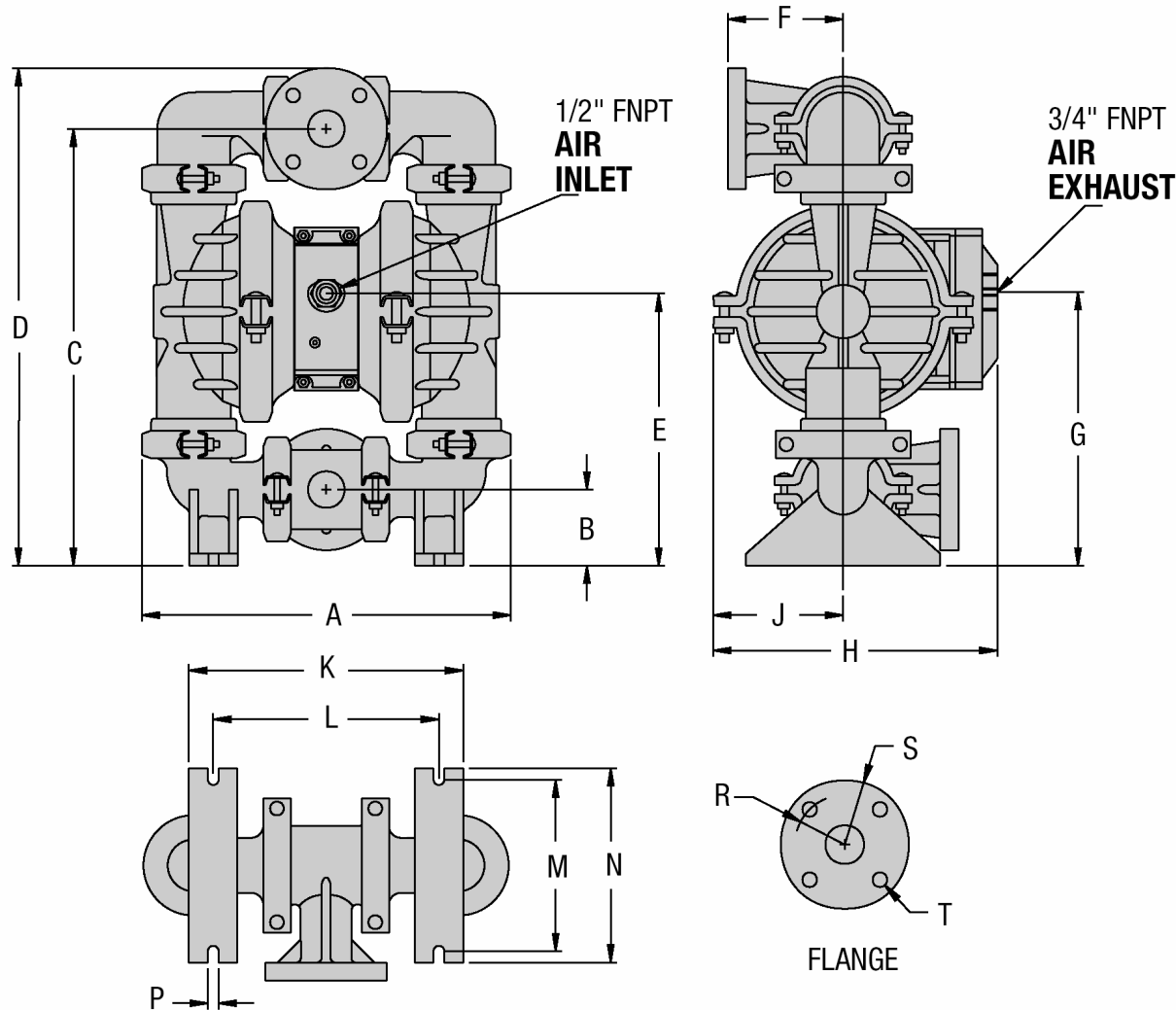

DIMENSIONS – P4 PLASTIC		
ITEM	METRIC (mm)	STANDARD (inch)
A	393.7	15 1/2
B	79.4	3 1/8
C	463.6	18 1/4
D	527.1	20 3/4
E	291.3	11 15/32
F	120.7	4 3/4
G	287.3	11 5/16
H	300.8	11 27/32
J	141.3	5 9/16
K	287.4	11 5/16
L	237.3	9 11/32
M	181.0	7 1/8
N	204.8	8 1/16
P	11.9	15/32
	METRIC (mm)	STANDARD (inch)
R	55.2 RAD.	1 15/16 RAD.
S	75.2 RAD.	2 1/2 RAD.
T	18.0 RAD.	9/16 DIA.

