

TECHNIQUES DES FLUIDES

10 Rue Jean Poulmarch, bat. 3
 Z.I. Du Val d'Argent
 95100 Argenteuil
 Tel. : 01.34.11.13.73 / Fax : 01.34.11.96.35

E-mail : tdf@techniquesfluides.fr
 Site web : www.techniquesfluides.fr



PX400 Aluminum

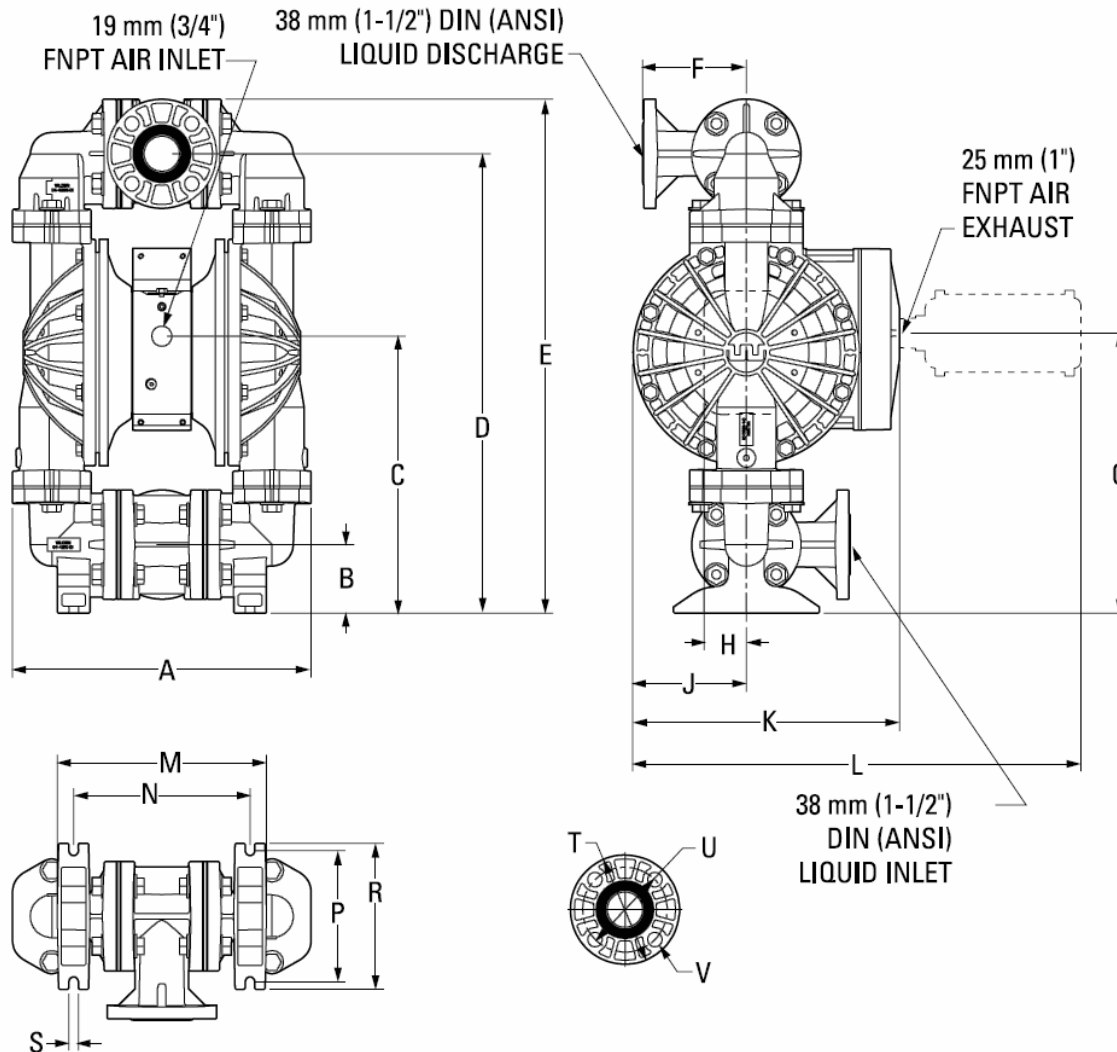

DIMENSIONS

ITEM	METRIC (mm)	STANDARD (inch)
A	343	13.5
B	79	3.1
C	323	12.7
D	531	20.9
E	594	23.4
F	122	4.8
G	325	12.8
H	48	1.9
J	132	5.2
K	310	12.2
L	521	20.5
M	244	9.6
N	206	8.1
P	152	6.0
R	170	6.7
S	10	0.4
	DIN (mm)	ANSI (inch)
T	150 DIA.	5.0
U	110 DIA.	3.9
V	18 DIA.	0.6

TECHNIQUES DES FLUIDES

10 Rue Jean Poulmarch, bat. 3
 Z.I. Du Val d'Argent
 95100 Argenteuil
 Tel. : 01.34.11.13.73 / Fax : 01.34.11.96.35

E-mail : tdf@techniquesfluides.fr
 Site web : www.techniquesfluides.fr



PX400 ALUMINUM – RUBBER-FITTED

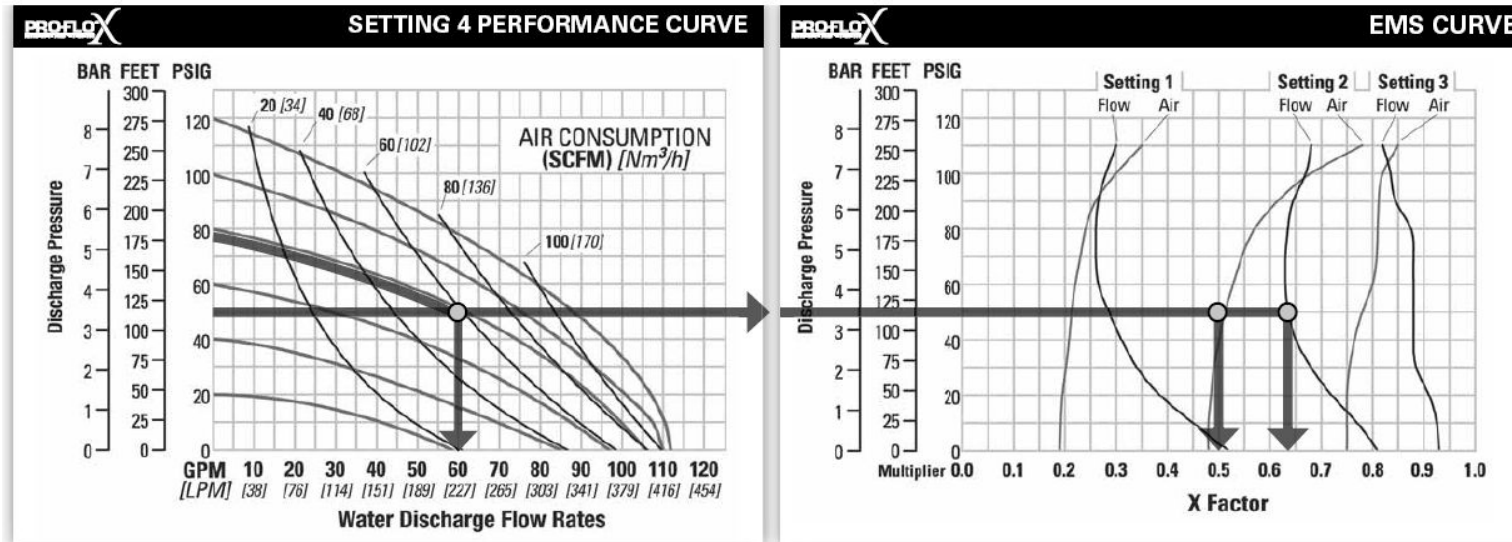

TECHNICAL DATA

Height	594 mm (23.4")
Width	343 mm (13.5")
Depth	310 mm (12.2")
Ship Weight	Aluminum 33 kg (72 lbs.)
Air Inlet	19 mm (3/4")
Inlet38 mm (1-1/2")
Outlet38 mm (1-1/2")
Suction Lift63 m Dry (20.5')
.....	9.0 m Wet (29.5')
Disp. Per Stroke	1.14 l (0.30 gal.) ¹
Max. Flow Rate	424 lpm (112 gpm)
Max. Size Solids	7.9 mm (5/16")

¹Displacement per stroke was calculated at 4.8 bar (70 psig) air inlet pressure against a 2 bar (30 psig) head pressure.

The Efficiency Management System (EMS) can be used to optimize the performance of your Wilden pump for specific applications. The pump is delivered with the EMS adjusted to setting 4, which allows maximum flow.

The EMS curve allows the pump user to determine flow and air consumption at each EMS setting. For any EMS setting and discharge pressure, the "X factor" is used as a multiplier with the original values from the setting 4 performance curve to calculate the actual flow and air consumption values for that specific EMS setting. Note: you can interpolate between the setting curves for operation at intermediate EMS settings.

EXAMPLE

A PX400 aluminum, Rubber-fitted pump operating at EMS setting 4, achieved a flow rate of 227 lpm (60 gpm) using 100 Nm^3/h (59 scfm) of air when run at 5.4 bar (79 psig) air inlet pressure and 3.4 bar (50 psig) discharge pressure (See dot on performance curve).

The end user did not require that much flow and wanted to reduce air consumption at his facility. He determined that EMS setting 2 would meet his needs. At 3.4 bar (50 psig) discharge pressure and EMS setting 2, the flow "X factor" is 0.63 and the air "X factor" is 0.52 (see dots on EMS curve).

Multiplying the original setting 4 values by the "X factors" provides the setting 2 flow rate of 143 lpm (38 gpm) and an air consumption of 52 Nm^3/h (31 scfm). The flow rate was reduced by 37% while the air consumption was reduced by 48%, thus providing increased efficiency.

For a detailed example for how to set your EMS, see beginning of performance curve section.

Caution: Do not exceed 8.6 bar (125 psig) air supply pressure.

The Efficiency Management System (EMS) can be used to optimize the performance of your Wilden pump for specific applications. The pump is delivered with the EMS adjusted to setting 4, which allows maximum flow.

TECHNIQUES DES FLUIDES

10 Rue Jean Poulmarch, bat. 3
 Z.I. Du Val d'Argent
 95100 Argenteuil
 Tel. : 01.34.11.13.73 / Fax : 01.34.11.96.35

E-mail : tdf@techniquesfluides.fr
 Site web : www.techniquesfluides.fr



PX400 ALUMINUM – TPE-FITTED

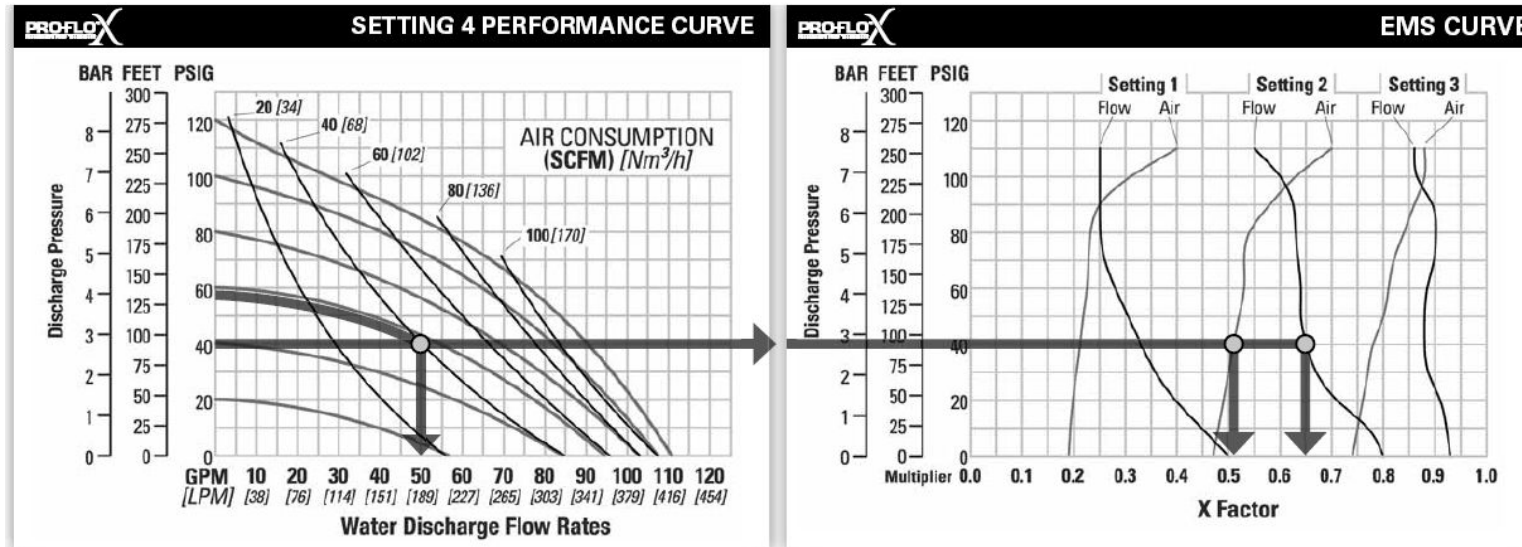

TECHNICAL DATA

Height 594 mm (23.4")
 Width 343 mm (13.5")
 Depth 310 mm (12.2")
 Ship Weight Aluminum 33 kg (72 lbs.)
 Air Inlet 19 mm (3/4")
 Inlet 38 mm (1-1/2")
 Outlet 38 mm (1-1/2")
 Suction Lift 5.2 m Dry (17')
 8.8 m Wet (28.9')
 Disp. Per Stroke 1.17 l (0.31 gal.)¹
 Max. Flow Rate 420 lpm (111 gpm)
 Max. Size Solids 7.9 mm (5/16")

¹Displacement per stroke was calculated at 4.8 bar (70 psig) air inlet pressure against a 2 bar (30 psig) head pressure..

The Efficiency Management System (EMS) can be used to optimize the performance of your Wilden pump for specific applications. The pump is delivered with the EMS adjusted to setting 4, which allows maximum flow.

The EMS curve allows the pump user to determine flow and air consumption at each EMS setting. For any EMS setting and discharge pressure, the "X factor" is used as a multiplier with the original values from the setting 4 performance curve to calculate the actual flow and air consumption values for that specific EMS setting. Note: you can interpolate between the setting curves for operation at intermediate EMS settings.

EXAMPLE

A PX400 aluminum, TPE-fitted pump operating at EMS setting 4, achieved a flow rate of 189 lpm (50 gpm) using 68 Nm³/h (40 scfm) of air when run at 4.0 bar (58 psig) air inlet pressure and 2.8 bar (40 psig) discharge pressure (See dot on performance curve).

The end user did not require that much flow and wanted to reduce air consumption at his facility. He determined that EMS setting 2 would meet his needs. At 2.8 bar (40 psig) discharge pressure and EMS setting 2, the flow "X factor" is 0.65 and the air "X factor" is 0.51 (see dots on EMS curve).

Multiplying the original setting 4 values by the "X factors" provides the setting 2 flow rate of 123 lpm (33 gpm) and an air consumption of 35 Nm³/h (20 scfm). The flow rate was reduced by 35% while the air consumption was reduced by 49%, thus providing increased efficiency.

For a detailed example for how to set your EMS, see beginning of performance curve section.

Caution: Do not exceed 8.6 bar (125 psig) air supply pressure.

The Efficiency Management System (EMS) can be used to optimize the performance of your Wilden pump for specific applications. The pump is delivered with the EMS adjusted to setting 4, which allows maximum flow.

TECHNIQUES DES FLUIDES

10 Rue Jean Poulmarch, bat. 3
 Z.I. Du Val d'Argent
 95100 Argenteuil
 Tel. : 01.34.11.13.73 / Fax : 01.34.11.96.35

E-mail : tdf@techniquesfluides.fr
 Site web : www.techniquesfluides.fr



PX400 ALUMINUM – PTFE-FITTED

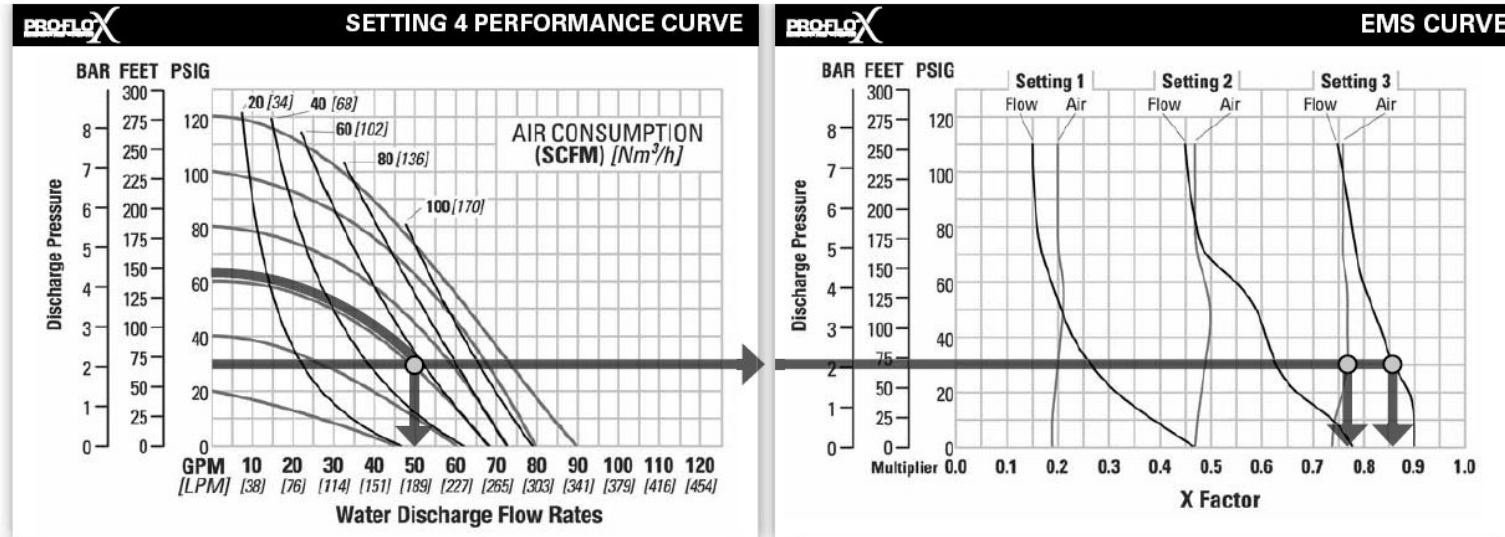

TECHNICAL DATA

Height594 mm (23.4")
Width343 mm (13.5")
Depth310 mm (12.2")
Ship Weight	Aluminum 33 kg (72 lbs.)
Air Inlet	19 mm (3/4")
Inlet38 mm (1-1/2")
Outlet38 mm (1-1/2")
Suction Lift	3.5 m Dry (11.4')
.....	9.0 m Wet (29.5')
Disp. Per Stroke	0.64 l (0.17 gal.) ¹
Max. Flow Rate338 lpm (89 gpm)
Max. Size Solids	7.9 mm (5/16")

¹Displacement per stroke was calculated at 4.8 bar (70 psig) air inlet pressure against a 2 bar (30 psig) head pressure.

The Efficiency Management System (EMS) can be used to optimize the performance of your Wilden pump for specific applications. The pump is delivered with the EMS adjusted to setting 4, which allows maximum flow.

The EMS curve allows the pump user to determine flow and air consumption at each EMS setting. For any EMS setting and discharge pressure, the "X factor" is used as a multiplier with the original values from the setting 4 performance curve to calculate the actual flow and air consumption values for that specific EMS setting. Note: you can interpolate between the setting curves for operation at intermediate EMS settings.

EXAMPLE

A PX400 aluminum, PTFE-fitted pump operating at EMS setting 4, achieved a flow rate of 189 lpm (50 gpm) using 99 Nm³/h (58 scfm) of air when run at 4.3 bar (62 psig) air inlet pressure and 2.1 bar (30 psig) discharge pressure (See dot on performance curve).

The end user did not require that much flow and wanted to reduce air consumption at his facility. He determined that EMS setting 3 would meet his needs. At 2.1 bar (30 psig) discharge pressure and EMS setting 3, the flow "X factor" is 0.87 and the air "X factor" is 0.72 (see dots on EMS curve).

Multiplying the original setting 4 values by the "X factors" provides the setting 3 flow rate of 165 lpm (44 gpm) and an air consumption of 71 Nm³/h (42 scfm). The flow rate was reduced by 13% while the air consumption was reduced by 28%, thus providing increased efficiency.

For a detailed example for how to set your EMS, see beginning of performance curve section.

Caution: Do not exceed 8.6 bar (125 psig) air supply pressure.

The Efficiency Management System (EMS) can be used to optimize the performance of your Wilden pump for specific applications. The pump is delivered with the EMS adjusted to setting 4, which allows maximum flow.

TECHNIQUES DES FLUIDES

10 Rue Jean Poulmarch, bat. 3
 Z.I. Du Val d'Argent
 95100 Argenteuil
 Tel. : 01.34.11.13.73 / Fax : 01.34.11.96.35

E-mail : tdf@techniquesfluides.fr
 Site web : www.techniquesfluides.fr



PX400 ALUMINUM – ULTRA-FLEX™

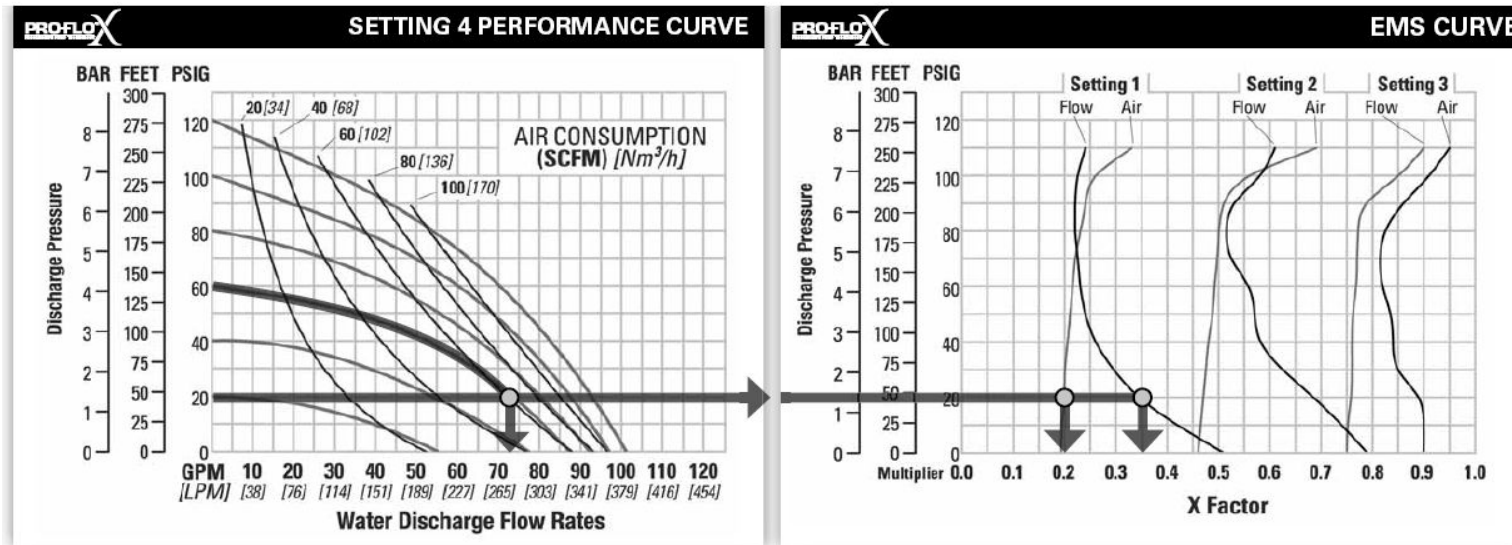

TECHNICAL DATA

Height594 mm (23.4")
Width343 mm (13.5")
Depth310 mm (12.2")
Ship Weight	Aluminum 33 kg (72 lbs.)
Air Inlet	19 mm (3/4")
Inlet38 mm (1-1/2")
Outlet38 mm (1-1/2")
Suction Lift	4.8 m Dry (15.9')
.....	9.0 m Wet (29.5')
Disp. Per Stroke	0.79 l (0.21 gal.) ¹
Max. Flow Rate3828 lpm (101 gpm)
Max. Size Solids	7.9 mm (5/16")

¹Displacement per stroke was calculated at 4.8 bar (70 psig) air inlet pressure against a 2 bar (30 psig) head pressure

The Efficiency Management System (EMS) can be used to optimize the performance of your Wilden pump for specific applications. The pump is delivered with the EMS adjusted to setting 4, which allows maximum flow.

The EMS curve allows the pump user to determine flow and air consumption at each EMS setting. For any EMS setting and discharge pressure, the "X factor" is used as a multiplier with the original values from the setting 4 performance curve to calculate the actual flow and air consumption values for that specific EMS setting. Note: you can interpolate between the setting curves for operation at intermediate EMS settings

EXAMPLE

A PX400 aluminum, Ultra-Flex-fitted pump operating at EMS setting 4, achieved a flow rate of 276 lpm (73 gpm) using 105 Nm³/h (62 scfm) of air when run at 4.1 bar (60 psig) air inlet pressure and 1.4 bar (20 psig) discharge pressure (See dot on performance curve).

The end user did not require that much flow and wanted to reduce air consumption at his facility. He determined that EMS setting 1 would meet his needs. At 1.4 bar (20 psig) discharge pressure and EMS setting 1, the flow "X factor" is 0.34 and the air "X factor" is 0.20 (see dots on EMS curve).

Multiplying the original setting 4 values by the "X factors" provides the setting 1 flow rate of 94 lpm (25 gpm) and an air consumption of 21 Nm³/h (12 scfm). The flow rate was reduced by 66% while the air consumption was reduced by 80%, thus providing increased efficiency.

For a detailed example for how to set your EMS, see beginning of performance curve section.

Caution: Do not exceed 8.6 bar (125 psig) air supply pressure.

The Efficiency Management System (EMS) can be used to optimize the performance of your Wilden pump for specific applications. The pump is delivered with the EMS adjusted to setting 4, which allows maximum flow.