

TECHNIQUES DES FLUIDES

10 Rue Jean Poulmarch, bat. 3
 Z.I. Du Val d'Argent
 95100 Argenteuil
 Tel. : 01.34.11.13.73 / Fax : 01.34.11.96.35

E-mail : tdf@techniquesfluides.fr
 Site web : www.techniquesfluides.fr



PX800 Aluminum

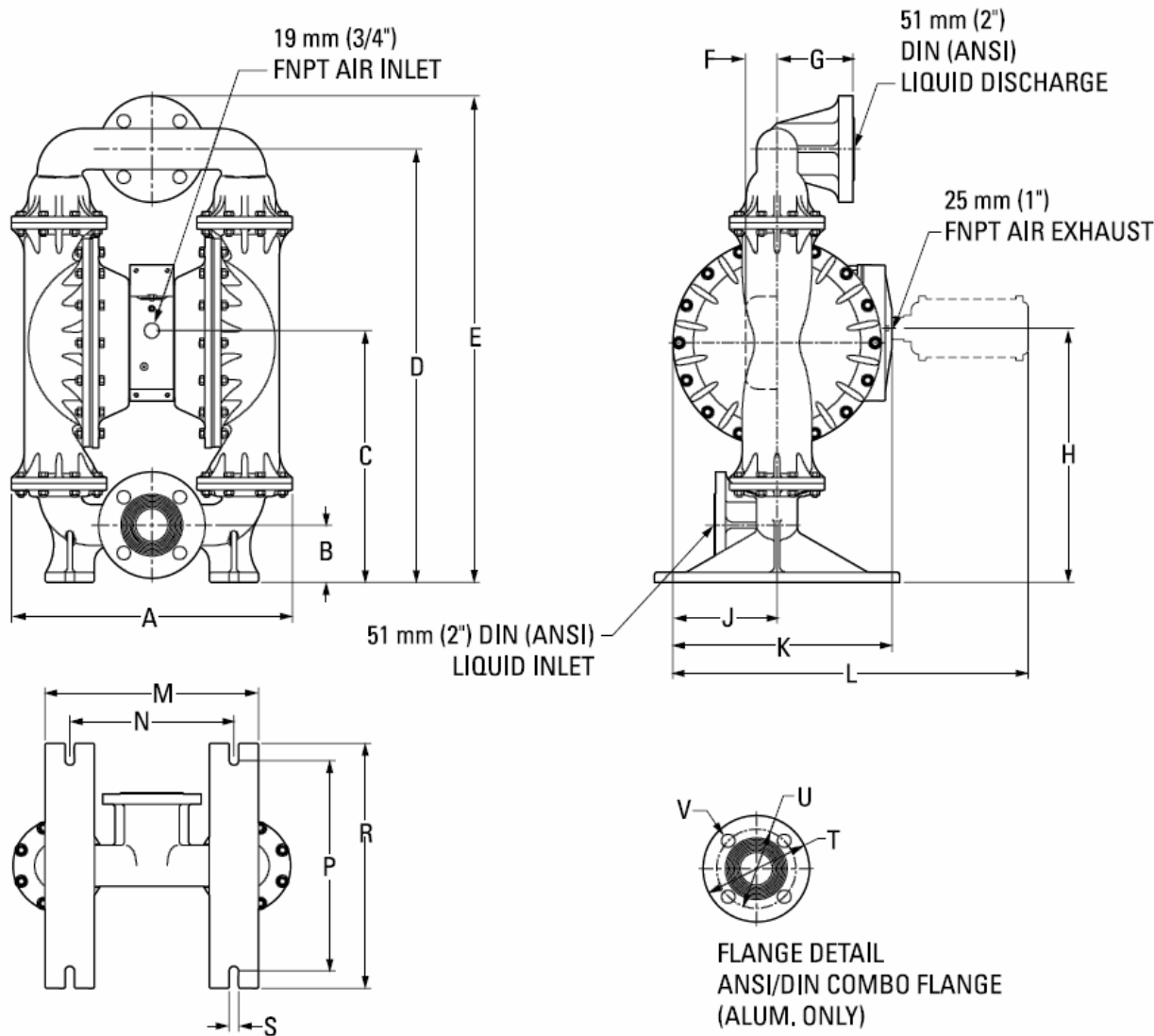

DIMENSIONS

ITEM	METRIC (mm)	STANDARD (inch)
A	439	17.3
B	89	3.5
C	396	15.6
D	676	26.6
E	759	29.9
F	48	1.9
G	117	4.6
H	399	15.7
J	163	6.4
K	340	13.4
L	551	21.7
M	330	13.0
N	254	10.0
P	325	12.8
R	378	14.9
S	15	0.6
ANSI/DIN COMBO		
T	165 DIA.	6.5 DIA.
U	122 DIA.	4.8 DIA.
V	20 DIA.	0.8 DIA.

TECHNIQUES DES FLUIDES

10 Rue Jean Poulmarch, bat. 3
 Z.I. Du Val d'Argent
 95100 Argenteuil
 Tel. : 01.34.11.13.73 / Fax : 01.34.11.96.35

E-mail : tdf@techniquesfluides.fr
 Site web : www.techniquesfluides.fr



PX800 Stainless Steel/Alloy C

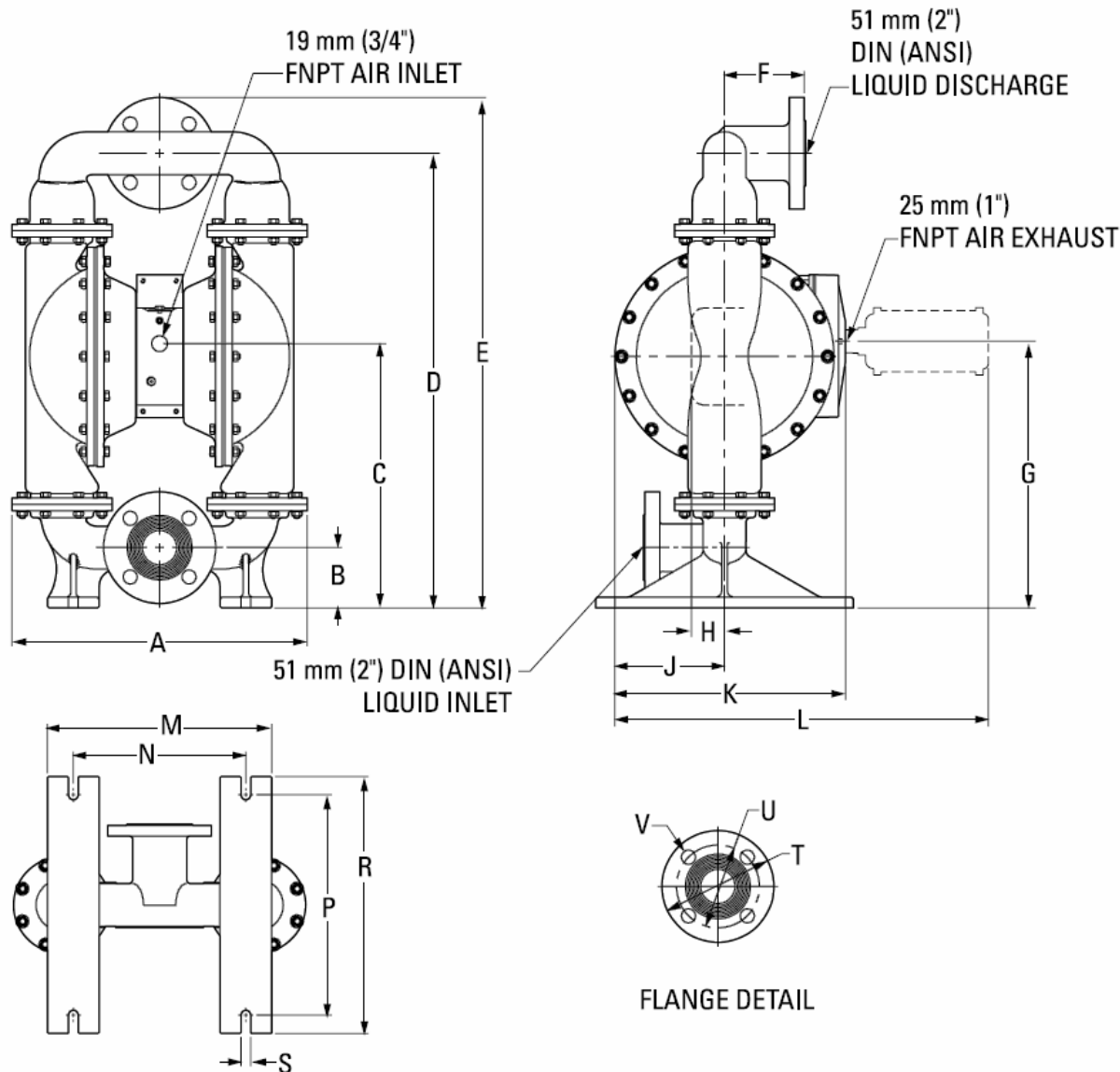

DIMENSIONS

ITEM	METRIC (mm)	STANDARD (inch)
A	434	17.1
B	89	3.5
C	391	15.4
D	678	26.7
E	759	29.9
F	117	4.6
G	394	15.5
H	48	1.9
J	163	6.4
K	340	13.4
L	551	21.7
M	330	13.0
N	254	10.0
P	325	12.8
R	378	14.9
S	15	0.6
ANSI/DIN COMBO		
T	165 DIA.	6.5 DIA.
U	122 DIA.	4.8 DIA.
V	20 DIA.	0.8 DIA.

TECHNIQUES DES FLUIDES

10 Rue Jean Poulmarch, bat. 3
 Z.I. Du Val d'Argent
 95100 Argenteuil
 Tel. : 01.34.11.13.73 / Fax : 01.34.11.96.35

E-mail : tdf@techniquesfluides.fr
 Site web : www.techniquesfluides.fr



PX800 METAL RUBBER-FITTED

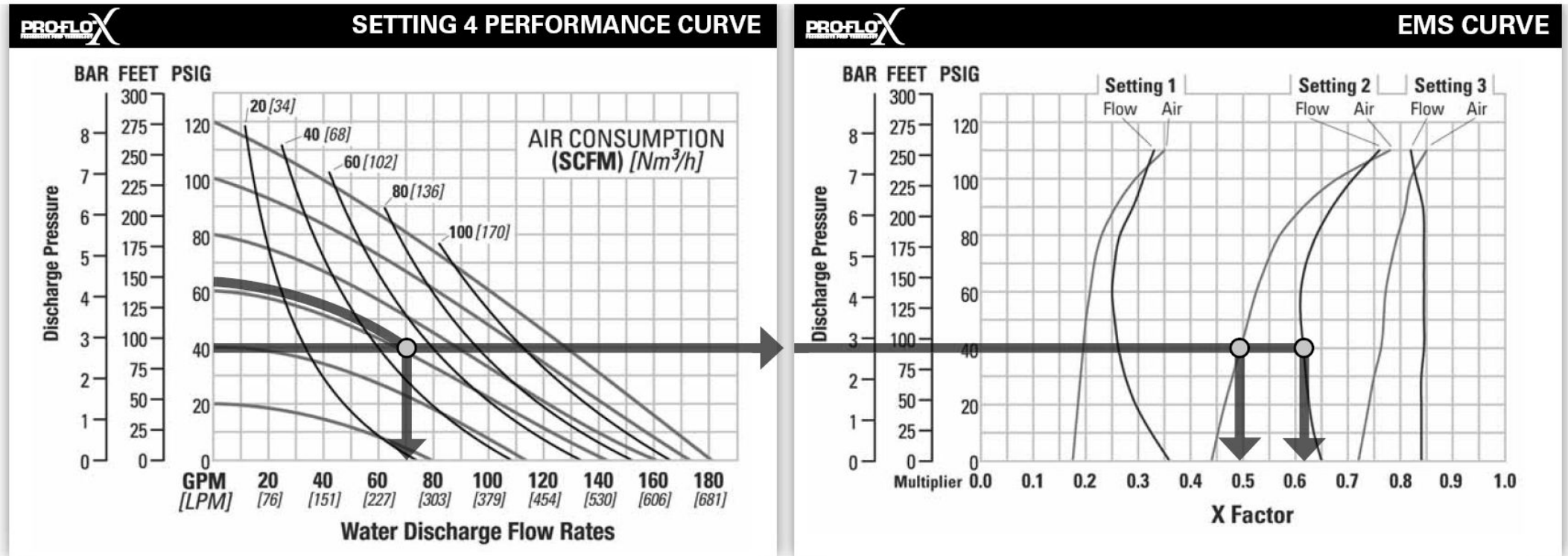

TECHNIQUES DES FLUIDES

10 Rue Jean Poulmarch, bat. 3
 Z.I. Du Val d'Argent
 95100 Argenteuil
 Tel. : 01.34.11.13.73 / Fax : 01.34.11.96.35

E-mail : tdf@techniquesfluides.fr
 Site web : www.techniquesfluides.fr



PX800 METAL TPE-FITTED

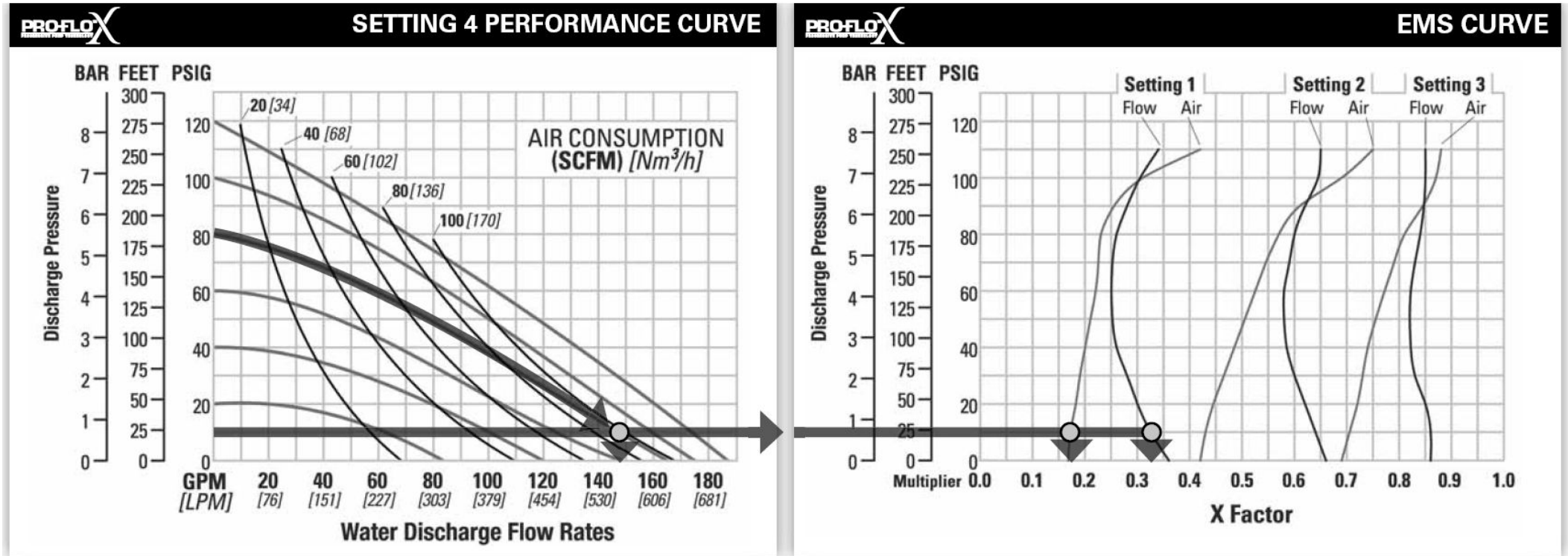

TECHNIQUES DES FLUIDES

10 Rue Jean Poulmarch, bat. 3
 Z.I. Du Val d'Argent
 95100 Argenteuil
 Tel. : 01.34.11.13.73 / Fax : 01.34.11.96.35

E-mail : tdf@techniquesfluides.fr
 Site web : www.techniquesfluides.fr



PX800 METAL ULTRA-FLEX™ FITTED

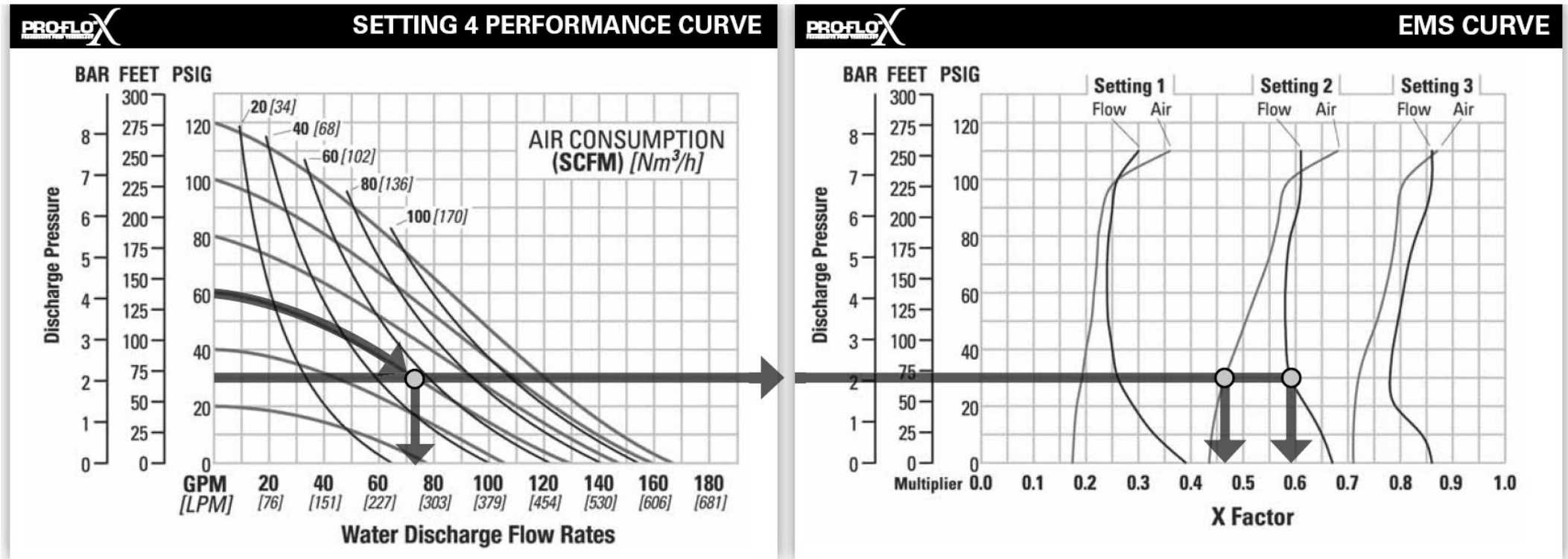

TECHNIQUES DES FLUIDES

10 Rue Jean Poulmarch, bat. 3
Z.I. Du Val d'Argent
95100 Argenteuil
Tel. : 01.34.11.13.73 / Fax : 01.34.11.96.35

E-mail : tdf@techniquesfluides.fr
Site web : www.techniquesfluides.fr



PX800 METAL PTFE-FITTED

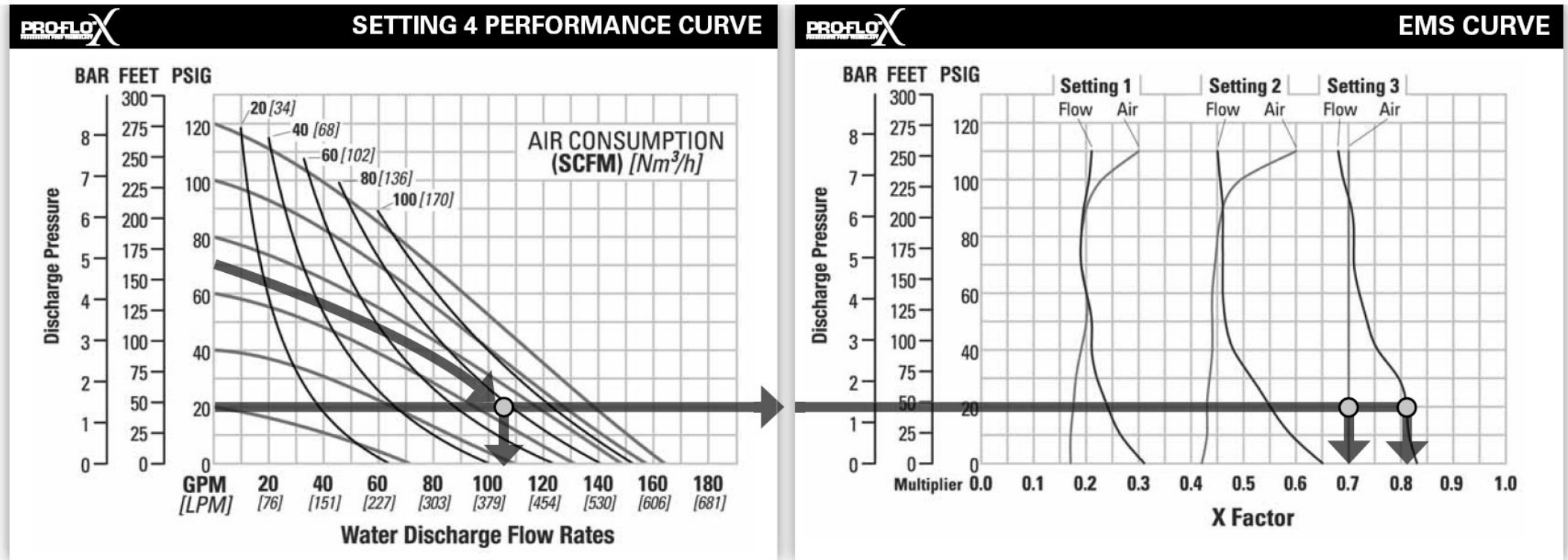

TECHNIQUES DES FLUIDES

10 Rue Jean Poulmarch, bat. 3
Z.I. Du Val d'Argent
95100 Argenteuil
Tel. : 01.34.11.13.73 / Fax : 01.34.11.96.35

E-mail : tdf@techniquesfluides.fr
Site web : www.techniquesfluides.fr



PX800 METAL SUCTION LIFT CAPABILITY

