

TECHNIQUES DES FLUIDES

10 Rue Jean Poulmarch, bat. 3
 Z.I. Du Val d'Argent
 95100 Argenteuil
 Tel. : 01.34.11.13.73 / Fax : 01.34.11.96.35

E-mail : tdf@techniquesfluides.fr
 Site web : www.techniquesfluides.fr



DIMENSIONAL DRAWING – FOOTED MODEL

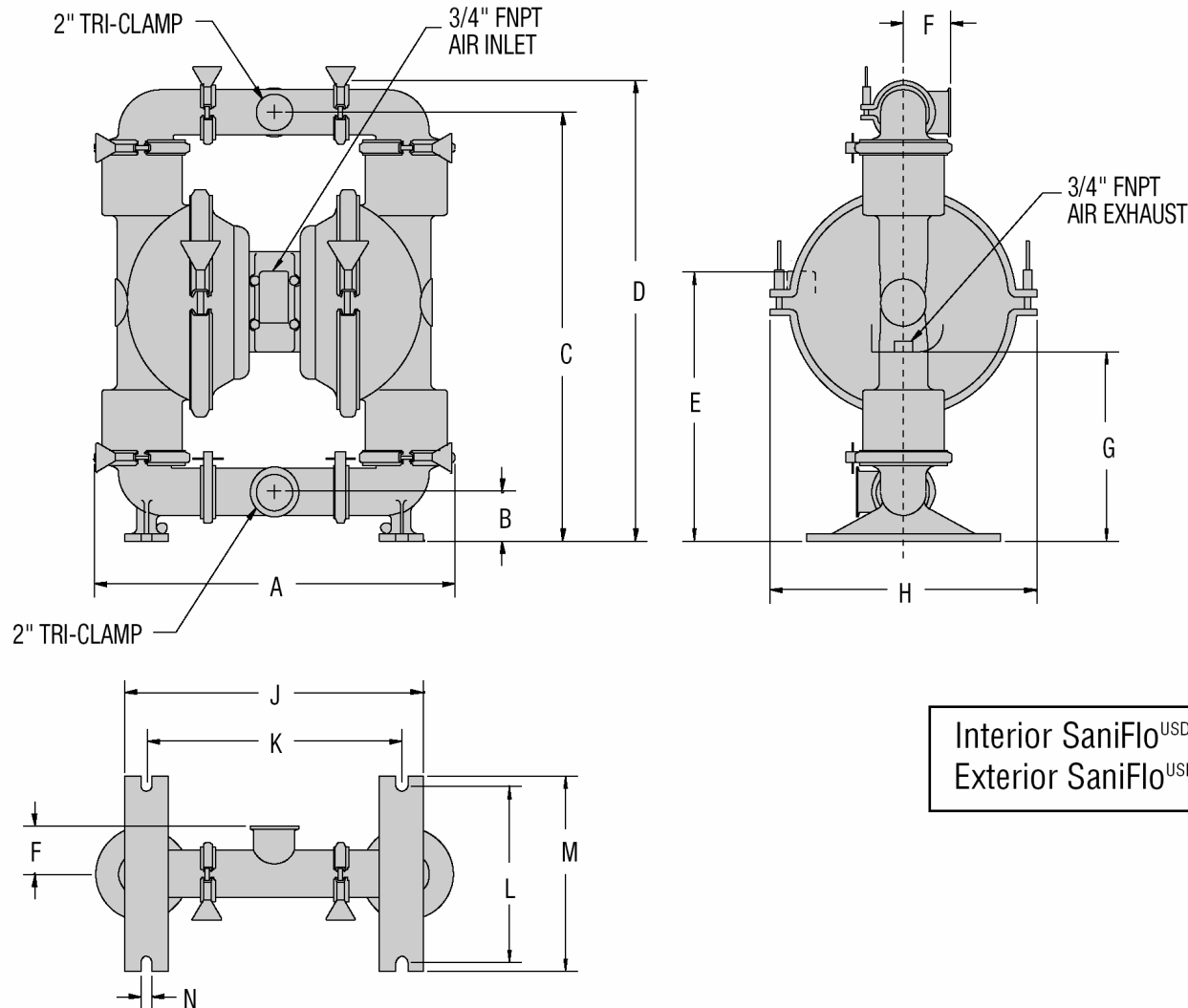

DIMENSIONS – T8 (SANIFLO ^{USDA})		
ITEM	METRIC (mm)	STANDARD (inch)
A	470.0	18.50
B	63.5	2.50
C	562.0	2.12
D	609.6	24
E	352.4	14.87
F	61.9	2.43
G	244.5	9.62
H	355.6	14
J	388.9	15.31
K	333.4	13.12
L	228.6	9
M	254.0	10
N	14.3	.56

Stand-mounted model available.

Interior SaniFlo^{USDA} finish is 150 Grit.
 Exterior SaniFlo^{USDA} finish is 320 Grit.

