

TECHNIQUES DES FLUIDES

10 Rue Jean Poulmarch, bat. 3

Z.I. Du Val d'Argent

95100 Argenteuil

Tel. : 01.34.11.13.73 / Fax : 01.34.11.96.35

E-mail : tdf@techniquesfluides.fr

Site web : www.techniquesfluides.fr



T810 ADVANCED™ METAL

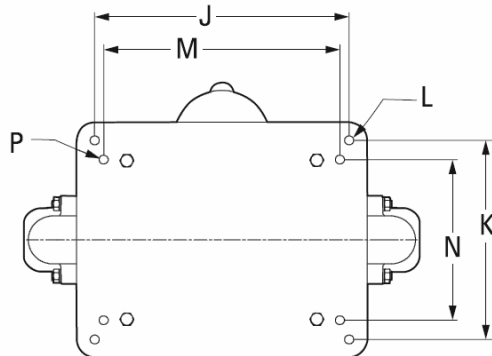
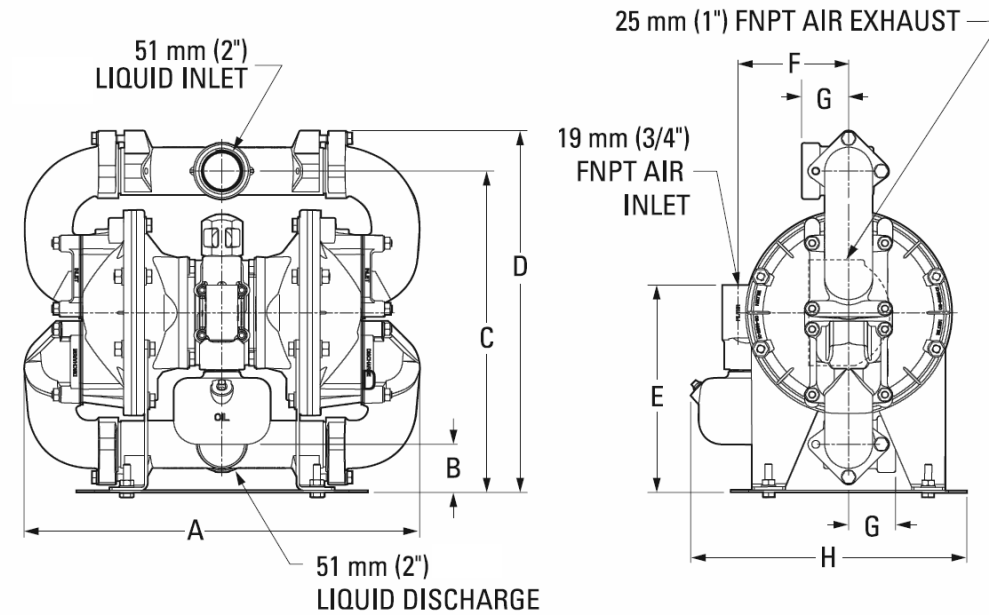

DIMENSIONS

ITEM	METRIC (mm)	STANDARD (inch)
A	554	21.8
B	69	2.7
C	452	17.8
D	508	20.0
E	292	11.5
F	155	6.1
G	66	2.6
H	386	15.2
J	356	14.0
K	279	11.0
L	13	0.5
M	330	13.0
N	226	8.9
P	13	0.5

