

# HYGHSPIN DF – hygienic high-pressure twin screw pumps.

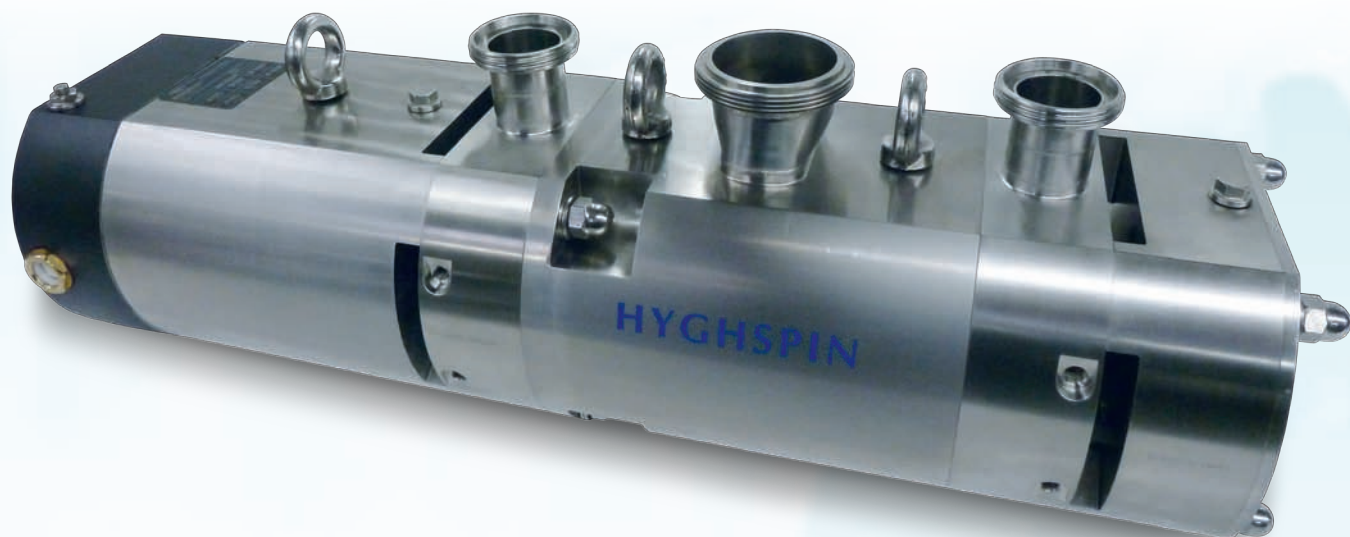

- Differential pressure up to 50 bar
- Double-suction
- Externally mounted
- Abrasion-free non-contact screws
- Axial feed concept for gentle treatment



# Focus on high-pressure applications.

Like the entire HYGHSPIN range, the double-suction high-pressure model HYGHSPIN DF was developed for highest demands with regard to precision and hygiene and complies with the quality requirements for the food and beverage industry and is also optimally suitable for many appliances in the chemical and pharmaceutical industry.

For demanding pumping tasks where heat exchangers or filtration units are used, HYGHSPIN DF is the pump of choice. Our in-house production offers flexibility and is certified as per ISO 9001:2008.



## Key features.

- Differential pressures up to 50 bar
- Double-suction pump with 2 product inlets and 1 outlet
- Externally mounted
- Abrasion-free non-contact screws even at high pressure differentials
- Axial gentle feeding of product
- Pumping of aqueous and highly viscous fluids
- Pumping of media containing pieces
- Feeding of gas-loaded fluids
- Same space requirements for double- and single-acting mechanical seals
- Hygienic sealing by form rings – no dead spaces
- FDA approved elastomers in different qualities

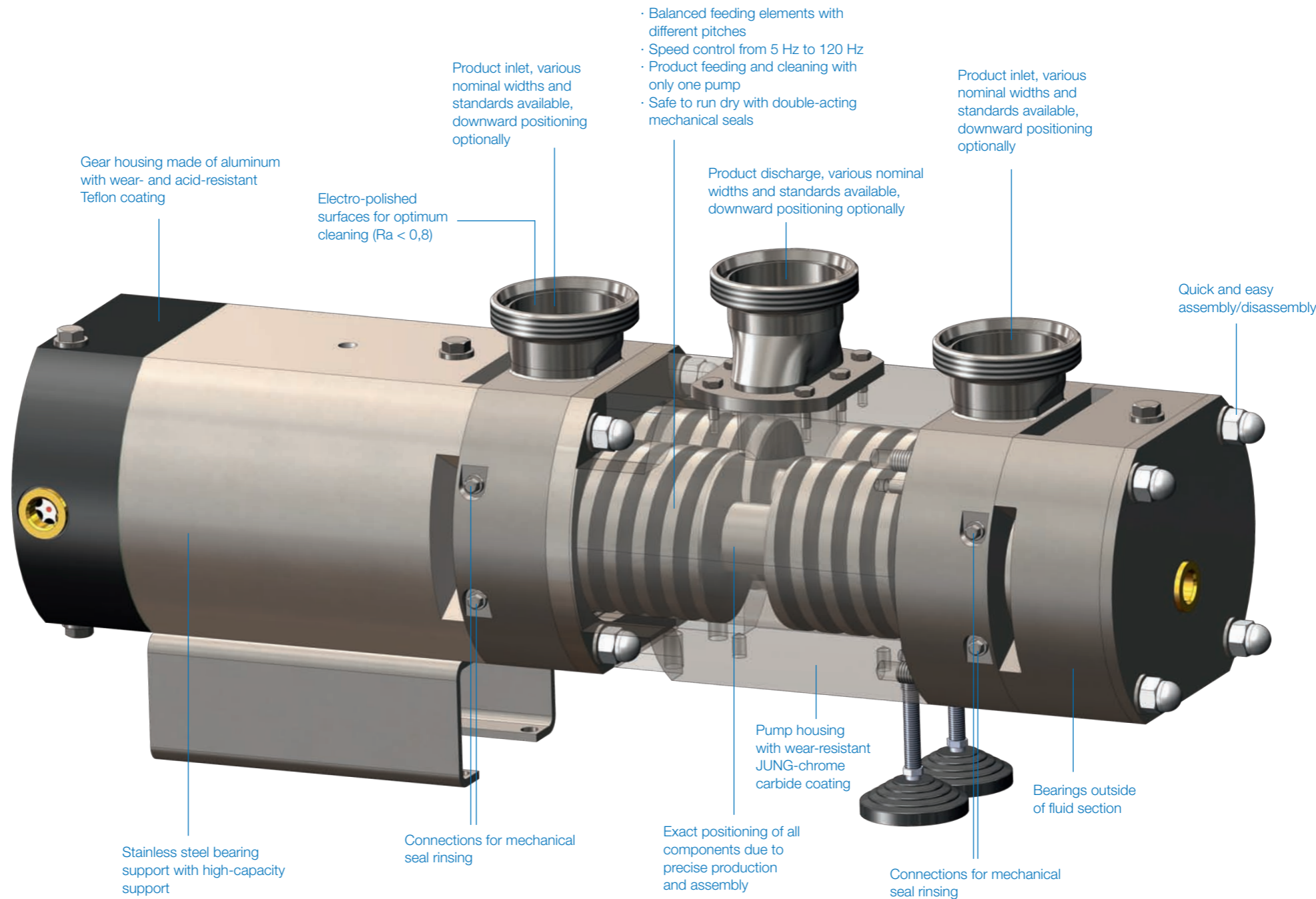

## One pump for numerous industries.

- Beverage industry
- Breweries
- Delicatessen industry
- Bakery products
- Confectionery
- Dairies
- Meat processing industry
- Personal and health care
- General industry



## Characteristic curves.

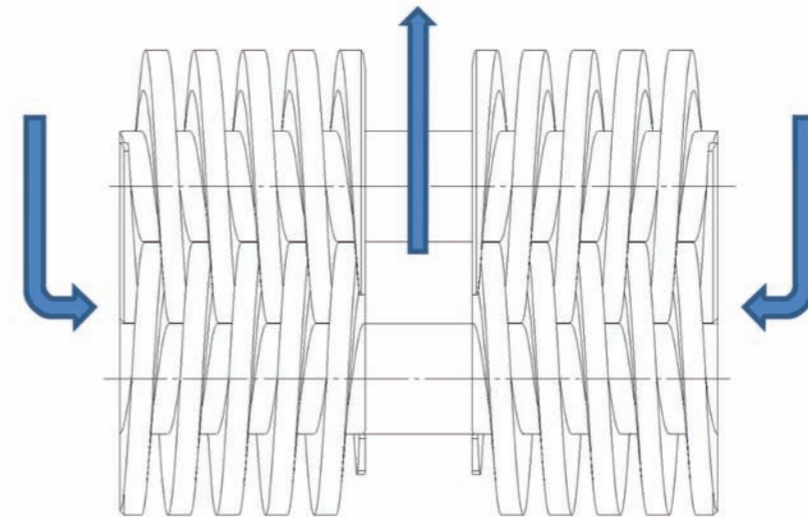
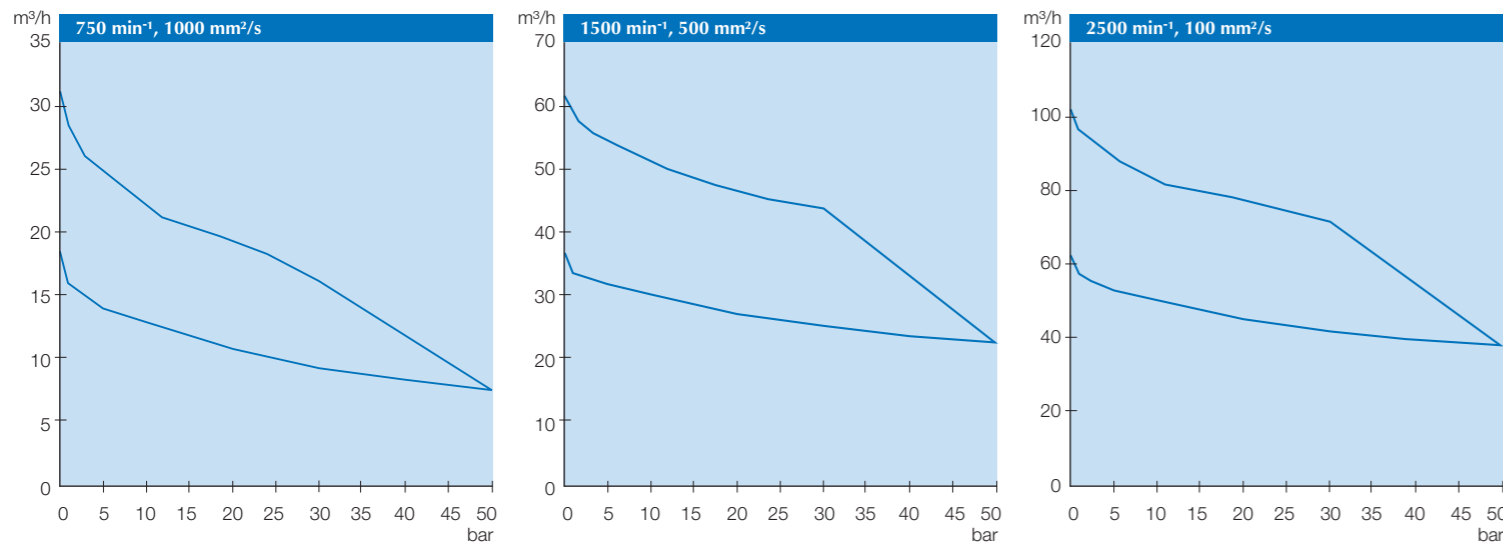

# Technical data.

## HYGHSPIN DF

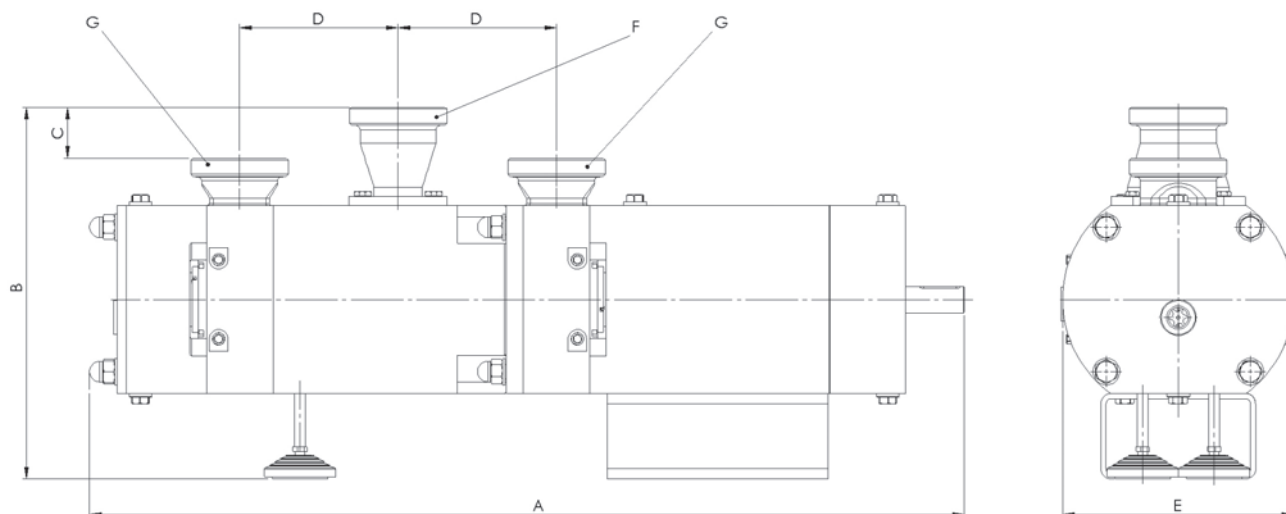

Type	Capacity	Max. diameter of solids Ø	Dimensions (mm)					Inlet	Outlet	Weight
			A	B	C	D	E			
HYGHSPIN 90DF	1 m³/h – 100 m³/h	19 mm	980	416	57	178	259	2" or DN50 2,5" or DN65	2,5" or DN65 3" or DN80	310 kg

## Overview.

Performance features	
Capacity	1 m³/h – 100 m³/h
Differential pressure	up to 50 bar
Suction capacity	NPSHr up to 0,5 m
Viscosity	0,5 – 1.000.000 cSt
Product temperature	-10 – 130° C, with oil cooler 160° C
Cleaning temperature	140° C
Sterilization temperature	up to 145° C
Product-contact parts made of	1.4404 with 3.1 certificate (other materials upon request)
Elastomers	HNBR and FDA approved (other elastomers upon request)



**TECHNIQUES DES FLUIDES**  
 7 rue de la Fosse aux Loups  
 95100 ARGENTEUIL  
 Tel. : 01 34 11 13 73  
 Fax : 01 34 11 96 35  
[www.techniquesfluides.fr](http://www.techniquesfluides.fr)

[www.jung-process-systems.de](http://www.jung-process-systems.de)

